

**SZM**

**SZM920 轮式装载机零部件图册**  
**SZM920 WHEEL LOADER PARTS CATALOGUE**

---

---

---

**青州山装机械有限公司**

**QINGZHOU SHANZHUANG (SZM) MACHINERY CO.,LTD.**

## 前言

SZM920 轮式装载机零部件图册，是为了用户在使用、维修和保养等工作中方便而绘制，以供在使用过程中查阅及参考，也可帮助用户了解本车的结构和装配关系。发动机另有专用的零部件图册，故本书未再绘出。

本图册按各总成及结构布局绘制出了各零部件的图形及相互装配关系。凡装机后不可拆卸的部件，(焊接件、铆合件)，一般只标出部件代号，不另列其组成零件，明细表采用中英文对照编排。

随着科技的进步和生产水平的提高，产品将会不断改进，本图册主要根据现行产品编绘说明，故本图册的内容将会有部分与以后的产品不一致，如有变动恕不通知。敬请用户在订购零部件时，指明所购整车的出厂日期和编号。

青州山装机械有限公司

## FOREWARD

This parts catalog of SZM920 wheel loader is intended as a consultation reference for the users to operate the machine, and to help them repair and maintain the loader, it can also help the users to be familiar with the construction and assembly relation of the machine. The engine has its own parts list. So this the parts catalog does not contain the engine part list.

The parts catalog accord the part drawing of different assemblies and struction distribution, showing the shape of the parts as well as the assembling relation. The components which can not be taken apart (lit the weldment or riveted assemblies) are indicated only by their component numbers without the consisting part numbers. The name list shows the part numbers, part names in English and Chinese. Alternations in design are necessary.

With the technical developing, specifications are subject to changed without notice before the parts catalog being recieved, and when ordering spare parts. Users are kindly requested to inform us. The manufacturing date and batch number of the wheel loader.

Qingzhou Shanzhuang (SZM) Machinery Co., Ltd.



# 目录 CONTENTS

图一	发动机系统 .....	(1)
FIG1	DIESEL ENGINE SYSTEM .....	(2)
图二	排气系统 .....	(3)
FIG2	EXHAUST SYSTEM .....	(4)
图三	空气滤清器 .....	(5)
FIG3	AIR FILTER ASSEMBLY .....	(6)
图四	散热器组合 .....	(7)
FIG4	RADIATOR ASSEMBLY .....	(8)
图五	油门操纵机构 .....	(9)
FIG5	GOVERNOR CONTROL SYSTEM .....	(10)
图六	熄火机构 .....	(11)
FIG6	CHOKE SYSTEM .....	(12)
图七	变矩器总成 .....	(13)
FIG7	TORQUE CONVERTER ASSEMBLY .....	(14)
图八	减压阀总成 .....	(15)
FIG8	RELIEF VALVE ASSEMBLY .....	(16)
图九	出油压力阀 .....	(17)
FIG9	OUTLET PRESSURE VALVE ASSEMBLY .....	(18)
图十	变速箱总成 .....	(19)
FIG10	GEARBOX ASSEMBLY .....	(20)
图十一	前进低档离合器总成 .....	(23)
FIG11	FRONT LOW CLUTCH ASSEMBLY .....	(24)
图十二	倒退高档离合器总成 .....	(25)
FIG12	REVERSE CLUTCH ASSEMBLY .....	(26)
图十三	变速操纵阀 .....	(27)
FIG13	GEAR SHIFT CONTROL VALVE .....	(28)
图十四	变速操纵机构 .....	(29)
FIG14	GEAR SHIFT CONTROL ASSEMBLY .....	(30)
图十五	传动液压系统 .....	(31)
FIG15	TRANSMISSION HYDRAULIC SYSTEM .....	(32)
图十六	滤油器总成 .....	(33)
FIG16	RETURN OIL FILTER ASSEMBLY .....	(34)
图十七	驱动桥总成 .....	(35)
FIG17	AXLE ASSEMBLY .....	(36)
图十八	主传动总成 .....	(37)
FIG18	MAIN REDUCER .....	(38)
图十九	后传动轴 .....	(39)
FIG19	REAR DRIVING SHAFT .....	(40)
图二十	前传动轴 .....	(41)
FIG20	FRONT DRIVING SHAFT .....	(42)
图二十一	轮胎轮辋总成 .....	(43)
FIG21	TYRE RIM MODULE .....	(44)
图二十二	制动液压系统 .....	(45)
FIG22	BRAKE CONTROL MECHANISM .....	(46)
图二十三	制动泵总成 .....	(47)
FIG23	BRAKE PUMP ASSEMBLY .....	(48)
图二十四	手制动操纵机构 .....	(49)
FIG24	BRAKE CONTROL MECHANISM .....	(50)
图二十五	手制动器总成 .....	(51)
FIG25	HAND BRAKE ASSEMBLY .....	(52)
图二十六	前车架总成 .....	(53)
FIG26	FRONT FRAME .....	(54)



# 目录 CONTENTS

图二十七	后车架总成 .....	( 55 )
FIG27	REAR FRAME .....	( 56 )
图二十八	铲斗总成 .....	( 57 )
FIG28	BUCKET ASSEMBLY .....	( 58 )
图二十九	工作装置总成 .....	( 59 )
FIG29	WORKING EQUIPMENT ASSEMBLY .....	( 60 )
图三十	配重铁总成 .....	( 61 )
FIG30	COUNTERWEIGHT ASSEMBLY .....	( 62 )
图三十一	发动机罩总成 .....	( 63 )
FIG31	HOOP OF DIESEL .....	( 64 )
图三十二	方向盘组合 .....	( 65 )
FIG32	STEERING WHEEL MODULE .....	( 66 )
图三十三	转向液压总成 .....	( 67 )
FIG33	STEERING SYSTEM .....	( 68 )
图三十四	转向器 .....	( 69 )
FIG34	ORBIT-ROOL VALYE .....	( 70 )
图三十五	优先阀总成 .....	( 71 )
FIG35	PRIORITY VALVE ASSEMBLY .....	( 72 )
图三十六	转向油缸 .....	( 73 )
FIG36	STEERING CYLINDER .....	( 74 )
图三十七	工作装置液压系统 .....	( 75 )
FIG37	IMPLEMENT HYDRAULIC SYSTEM .....	( 76 )
图三十八	翻斗油缸 .....	( 77 )
FIG38	DUMP CYLINDER .....	( 78 )
图三十九	动臂油缸 .....	( 79 )
FIG39	LIFT ARM CYLINDER .....	( 80 )
图四十	齿轮泵 .....	( 81 )
FIG40	GEAR PUMP .....	( 82 )
图四十一	油泵传动轴支架 .....	( 83 )
FIG41	SUPPORT DRIVING SHAFT OF PUMP .....	( 84 )
图四十二	多路阀 .....	( 85 )
FIG42	LOADER VALVE ASSEMBLY .....	( 86 )
图四十三	安全阀 .....	( 87 )
FIG43	SAFETY VALVE .....	( 88 )
图四十四	工作操纵机构 .....	( 89 )
FIG44	WORKING CONTEOL SYSEM .....	( 90 )
图四十五	机油箱总成 .....	( 91 )
FIG45	HYDRAULIC TANK ASSEMBLY .....	( 92 )
图四十六	柴油箱总成 .....	( 93 )
FIG46	FUEI TANK ASSEMBLY .....	( 94 )
图四十七	操纵台架总成 .....	( 95 )
FIG47	CONSOLE SUPPORT ASSEMBLY .....	( 96 )
图四十八	驾驶室总成 .....	( 97 )
FIG48	CAGE ASSEMBLY .....	( 98 )
图四十九	座椅总成 .....	( 99 )
FIG49	SEAT ASSEMBLY .....	( 100 )
图五十	驾驶室操纵台 .....	( 101 )
FIG50	CAGE CONSOLE SUPPORT .....	( 102 )
图五十一	仪表盘总成 .....	( 103 )
FIG51	CONTROL PANEL ASSEMBLY .....	( 104 )
图五十二	电气系统 .....	( 105 )
FIG52	ELECTRIC SYSTEM .....	( 106 )



发动机系统

DIESEL ENGINE MOUNT

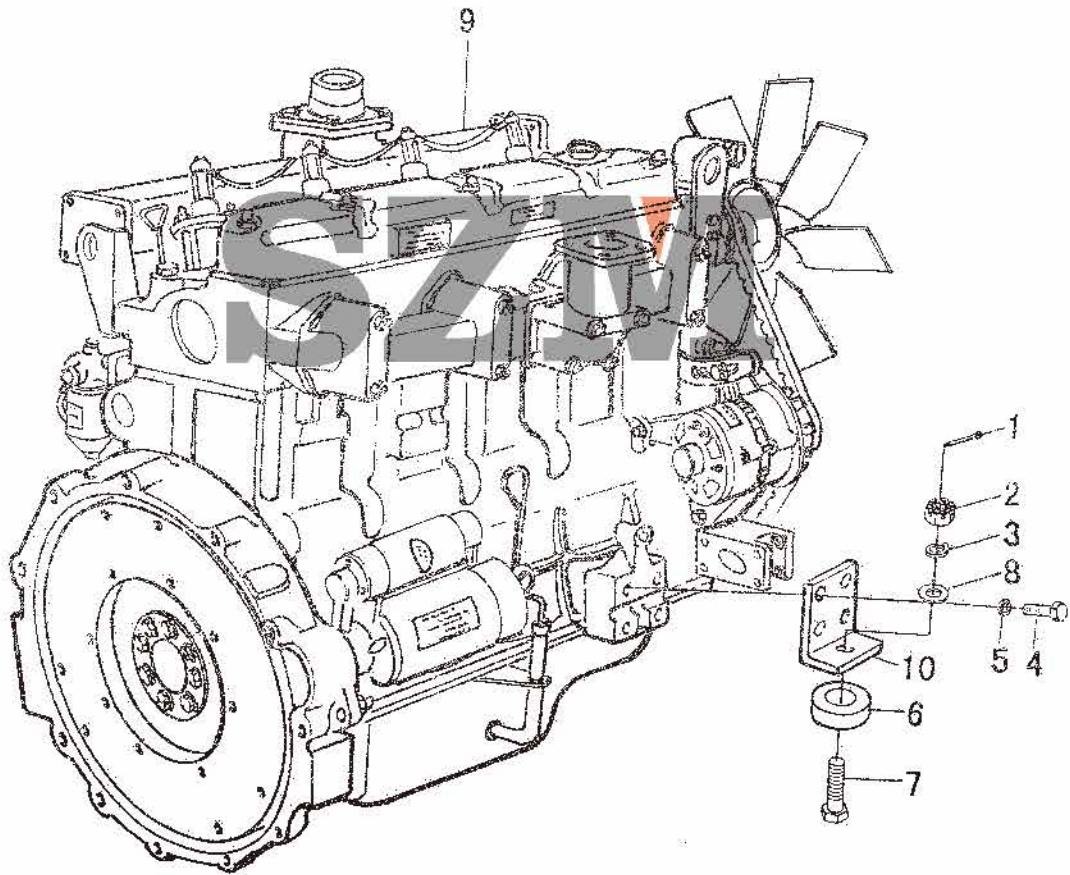

# 青州山装

序号 KEY	件号 PART NO.	名称 DESCRIPTION	数量 QTY
1	GB/T91-2000	开口销 1.6	2
2	GB/T6178-1986	花螺母 M12	2
3	GB/93-1987	垫圈 12	2
4	GB/T5783-2000	螺栓 M 10 × 30	8
5	GB/T93-1987	垫圈 10	8
6		橡胶垫	2
7	GB/T5783-2000	螺栓 M12 × 60	2
8	GB/T97.1-2000	垫圈 12	2
9		发动机	1
10		发动机固定座	2

# SZM



排气系统

EXHAUST SYSTEM

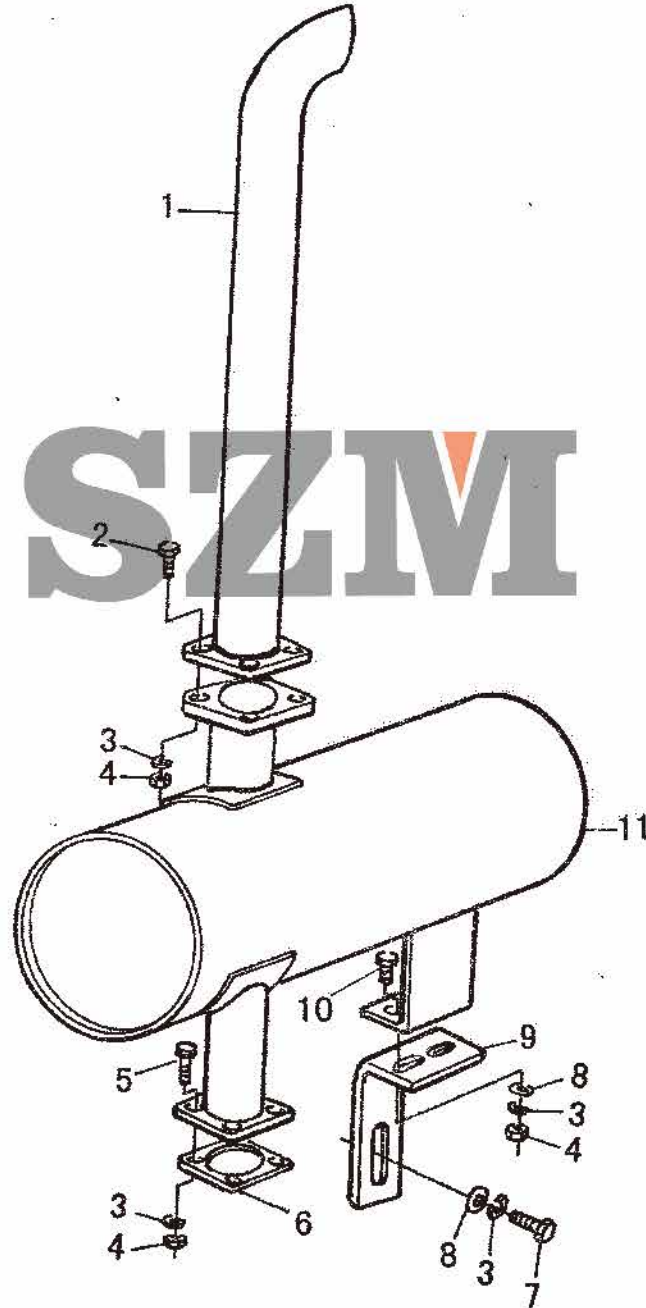

# 青州山装

序号 KEY	件号 PART NO.	名称 DESCRIPTION	数量 QTY
1		消音器排气管 EXHAUST PIPE	1
2	GB/T5783-2000	螺栓 M8 × 25 BOLT M8 × 25	4
3	GB/T93-1987	垫圈 8 WASHER 8	12
4	GB/T6170-2000	螺母 M8 NUT M8	10
5	GB/5783-2000	螺栓 M8 × 40 BOLT M8 × 40	4
6		纸垫 GASKET	1
7	GB/5783-2000	螺栓 M8 × 20 BOLT M8 × 20	2
8	GB/97.1-2002	垫圈 8 WASHER 8	4
9		消音器支架板 SUPPORT PLATE	1
10	GB/T5783-2000	螺栓 M8 × 30 BOLT M8 × 30	2
11		消音器 SILENCER BODY	1

# SZM



空气滤清器

AIR FILTER ASSEMBLY

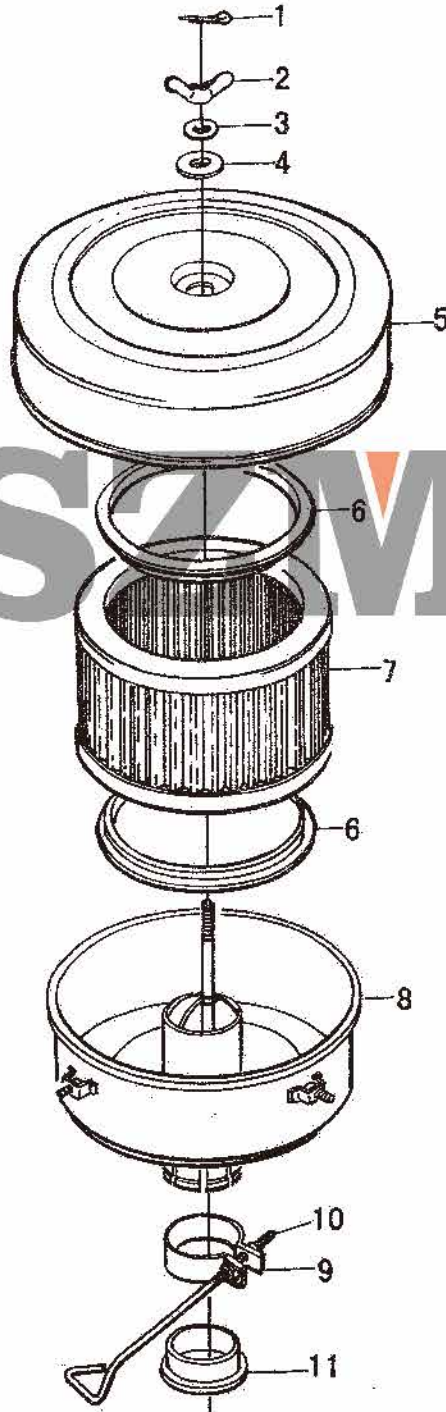

# 青州山装

序号 KEY	件号 PART NO.	名称 DESCRIPTION	数量 QTY	
1		开口销	SPLIT PIN	1
2		蝶形螺母	NUT	1
3		小垫圈	WASHER	1
4		大垫圈	WASHER	1
5		上盖	UPPER COVER	1
6		密封圈	SEAL RING	2
7		滤芯	FINE FILTER ASS' Y	1
8		下盖	LOWER COVER	1
9		卡箍	CLAMP	1
10		锁紧拉杆	LOCK PULL ROD	1
11		座	SEAT	1

# SZM



散热器組合

RADIATOR ASSEMBLY

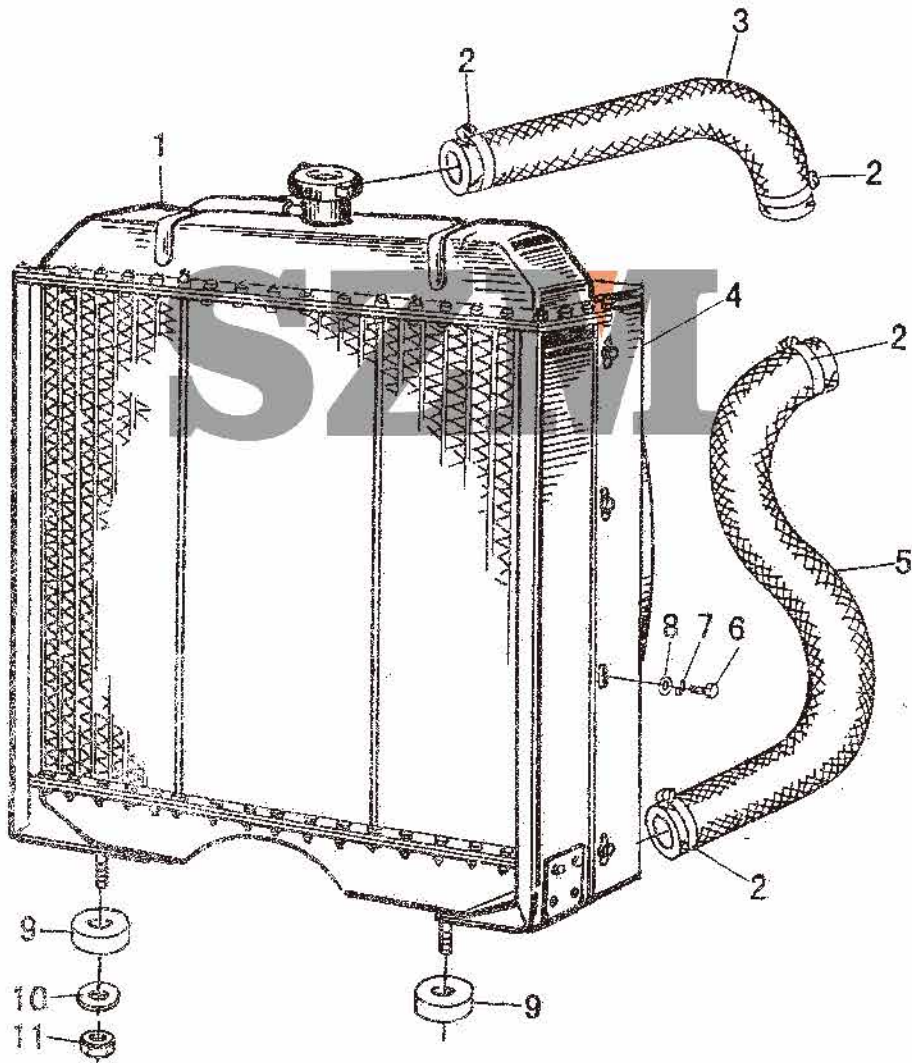

# 青州山装

序号 KEY	件号 PART NO.	名称 DESCRIPTION	数量 QTY
1		水箱总成	1
2	JB/T8870-1999	喉箍 d35-51	4
3		发动机出水管	1
4		兜风圈	1
5		发动机进水管	1
6	GB/T5783-2000	螺栓 M6 × 20	8
7	GB/T93-1987	垫圈 6	8
8	GB/T97.1-2002	垫圈 6	8
9		橡胶垫	2
10	GB/T93-1987	垫圈 12	2
11	GB/T6170-2000	螺母 M12	2

# SZM

油门操纵机构

GOVERNOR CONTROL SYSTEM

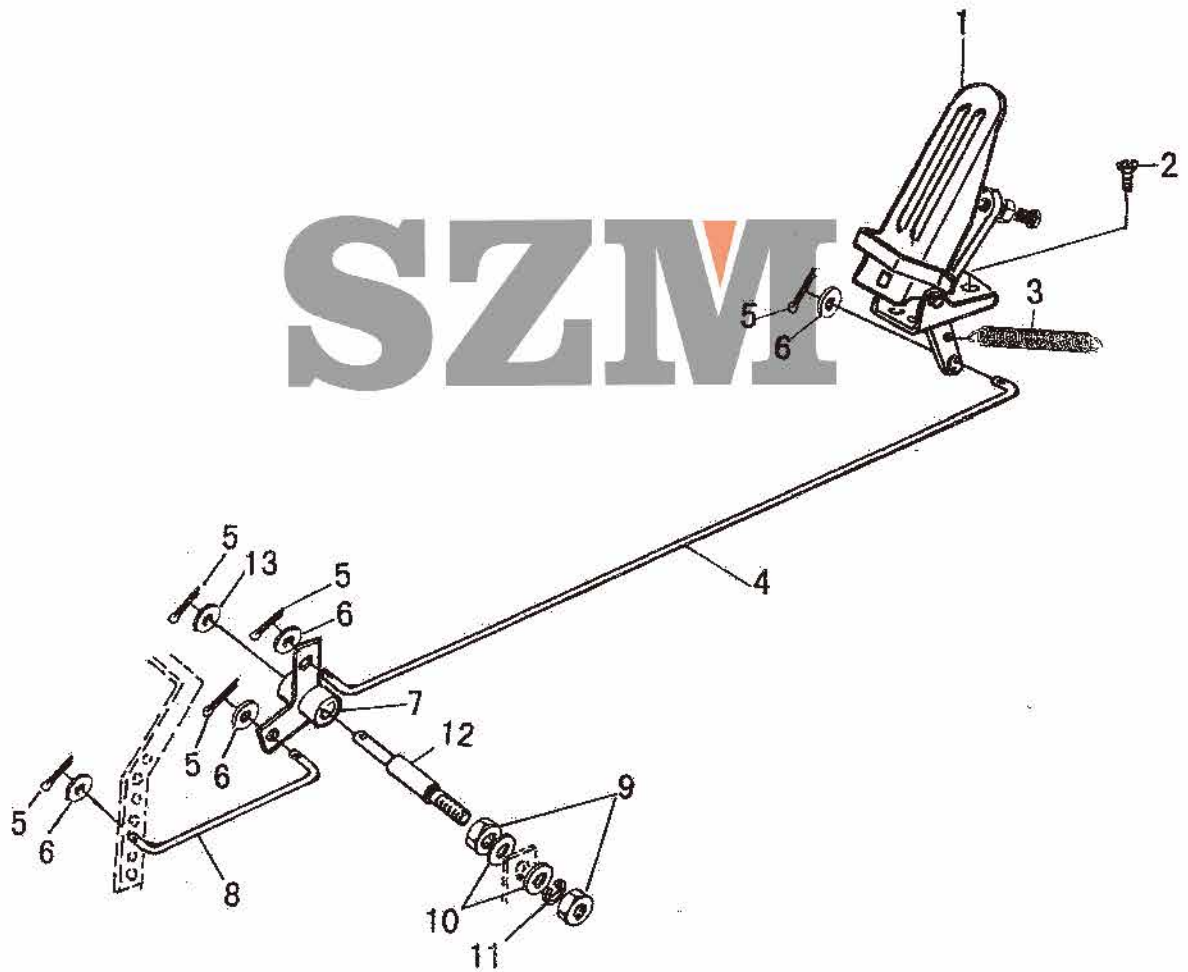

# 青州山装

序号 KEY	件号 PART NO.	名称 DESCRIPTION	数量 QTY
1		油门踏板	1
2	GB/T68-2000	螺钉 M6 × 20	3
3		扣簧	1
4		油门拉杆Ⅲ	1
5	GB/T91-2000	开口销 2.8 × 16	5
6	GB/T97.1-2000	垫圈 6	4
7		油门摆臂组件	1
8		油门拉杆Ⅱ	1
9	GB/T6170-2000	螺母 M10	2
10	GB/T97.1-2000	垫圈 10	2
11	GB/T93-1987	垫圈 10	1
12		油门拉杆Ⅰ	1
13	GB/T97.1-2000	垫圈 8	1

# SZM



熄火机构

CHOKE SYSTEM

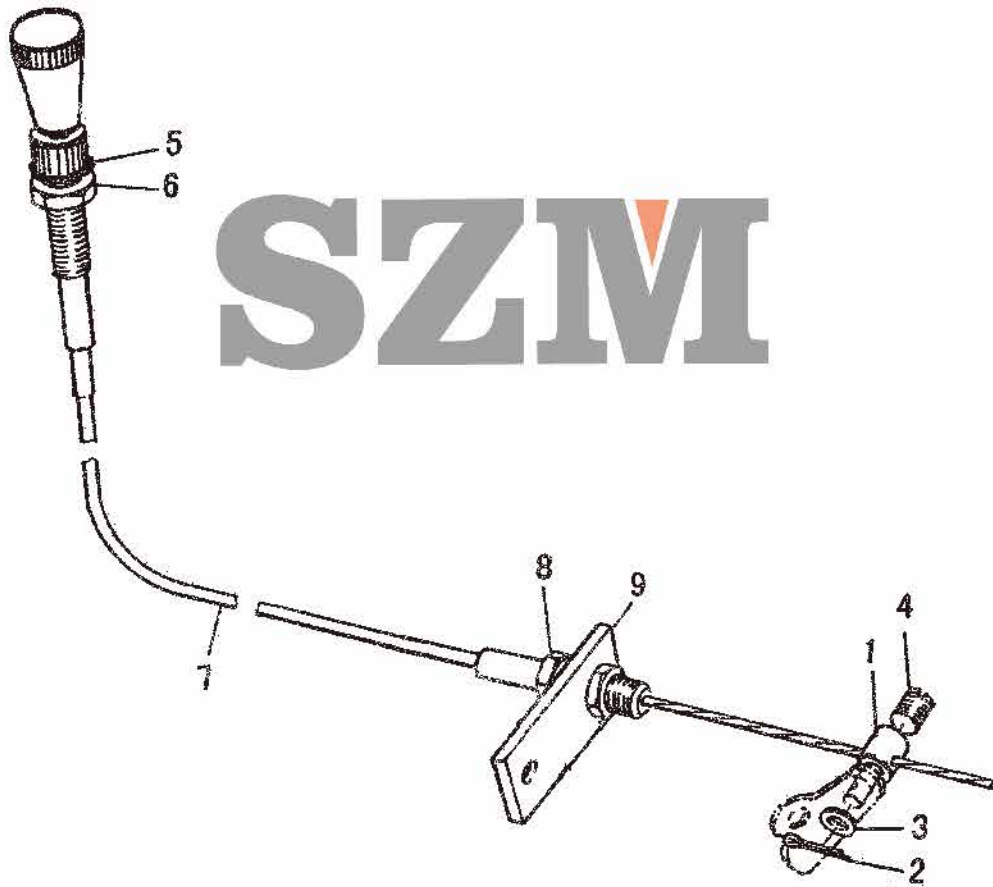

# 青州山装

序号 KEY	件号 PART NO.	名称 DESCRIPTION	数量 QTY
1		螺栓轴	1
2	GB91-1986	开口销 2 × 10	1
3	GB97.1-1985	垫圈 6	1
4	GB75-1985	紧定螺钉 M6 × 10-Ep · Zn	1
5	GB97.1-1985	垫圈 10	1
6	GB41-1986	螺母 M10-Ep · Zn	1
7		操纵软轴	1
8	GB41-1986	螺母 M6-Ep · Zn	2
9		熄火联板	1

# SZM

变矩器总成

TORQUE CONVERTER

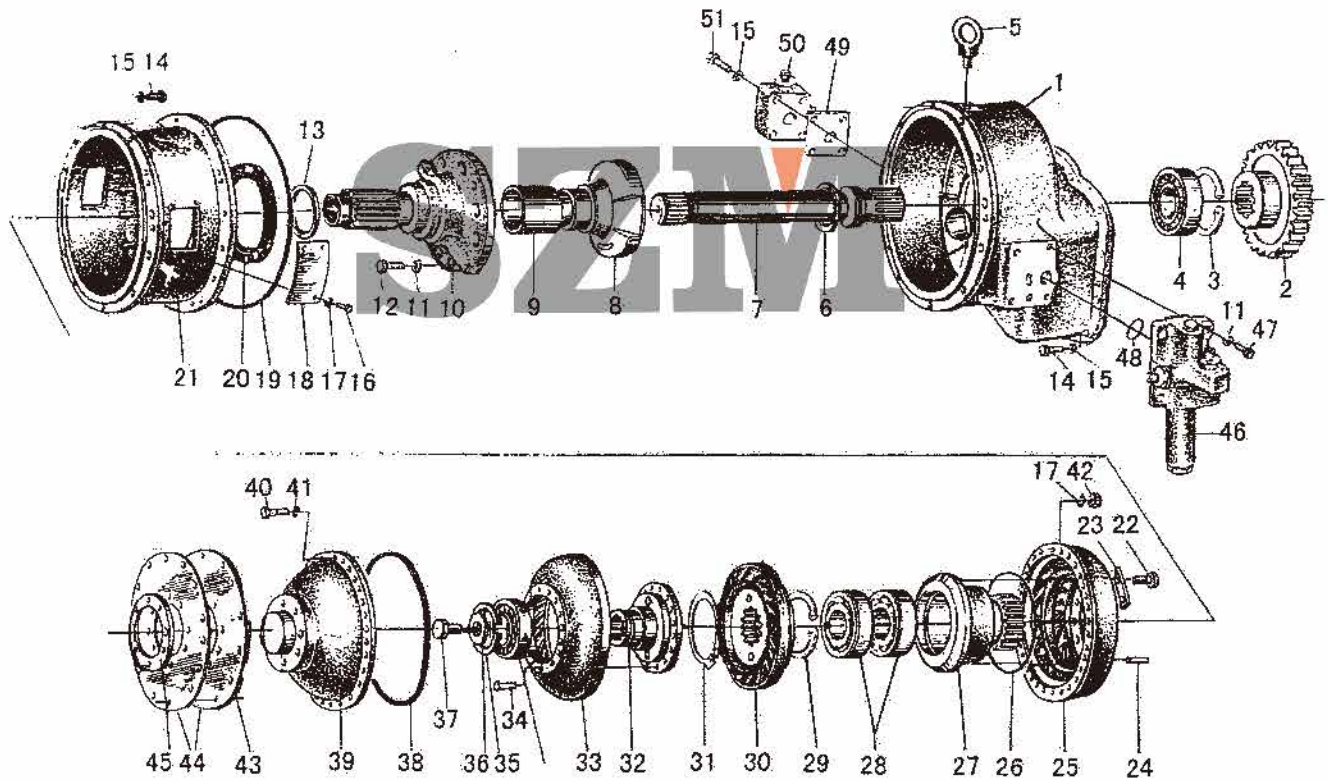

# 青州山装

序号 KEY	件号 PART NO.	名称 DESCRIPTION	数量 QTY	
1		箱体	HOUSING	1
2		主动齿轮	GEAR	1
3	GB893.1-86	挡圈 90	SNAP RING 90	1
4	GB276-89	轴承 308	BEARING 308	1
5	GB825-88	吊环螺钉 M10	SCREW M10	1
6		密封环	SEAL RING	1
7		主动轴	DRIVING SHAFT	1
8		导轮座、封油套	STATOR BOSS SLEEVE	1
9		套	SLEEVE	1
10		导轮座	STATOR BOSS	1
11	GB93-87	垫圈 10	WASHER 10	8
12	GB5783-86	螺栓 M10 × 35	BOLT M10 × 35	8
13		密封环	SEAL RING	1
14	GB5783-86	螺栓 M12 × 30	BOLT M12 × 30	12
15	GB93-87	垫圈 12	WASHER 12	12
16	GB5783-86	螺栓 M8 × 10	BOLT M8 × 10	8
17	GB93-87	垫圈 8	WASHER 8	8
18		盖板	COVER PLATE	2
19		O型密封圈	O-RING	1
20	HG4-692-67	油封	OIL SEAL	1
21		中节	MID-SEGMENT	1
22	GB5783-86	螺栓 M8 × 16	BOLT M8 × 16	6
23		双联垫片	DOUBLE SPACER	3
24	GB119-86	销 A8 × 16	PIN A8 × 16	4
25		泵轮	LMPELLER	1
26	GB3452.1-82	O型圈 106 × 3.55	O-RING 106 × 3.55	1
27		泵轮座	LMPELLER HUB	1
28	GB276-89	轴承 6108	BEARING 6108	3
29	GB893.1-86	挡圈 68	SNAP RING 68	1
30		导轮	STATOR	1
31	GB894.1-86	挡圈	SNAP RING	1
32		涡轮毂	TURBING HUB	1
33		涡轮	TURBINE	1
34	GB869-86	铆钉 6 × 42	RIVET 6 × 42	10
35	GB894.1-86	挡圈 40	SNAP RING 40	1
36		压垫 II	FILLER II	1
37	GB5783-86	螺栓 M8 × 20	BOLT M8 × 20	1
38		O型圈 279 × 3.55	O-RING 279 × 3.55	1
39		联接轮	LMPELLER SHELL	1
40	GB5782-86	螺栓 M8 × 60	BOLT M8 × 60	24
41	GB848-85	垫圈 8	WASHER 8	24
42	GB6170-86	螺母 M8	NUT M8	24
43		双联垫片	DOUBLE SPACER	6
44		弹性板	ELASTIC PLATE	2
45		压板	FILLER	1
46		减压阀总成	RELIEF VALVE	1
47	GB70-85	螺钉 M10 × 25	SCREW	4
48	GB3452.1-82	O型圈	O-RING	1
49		垫片	SEALING SPACER	1
50		出口压力阀总成	OUTLET PRESSURE VALVE	1
51	GB5782-86	螺栓 M10 × 90	BOLT M10 × 90	4



减压阀总成

RELIEF VALVE ASSEMBLY

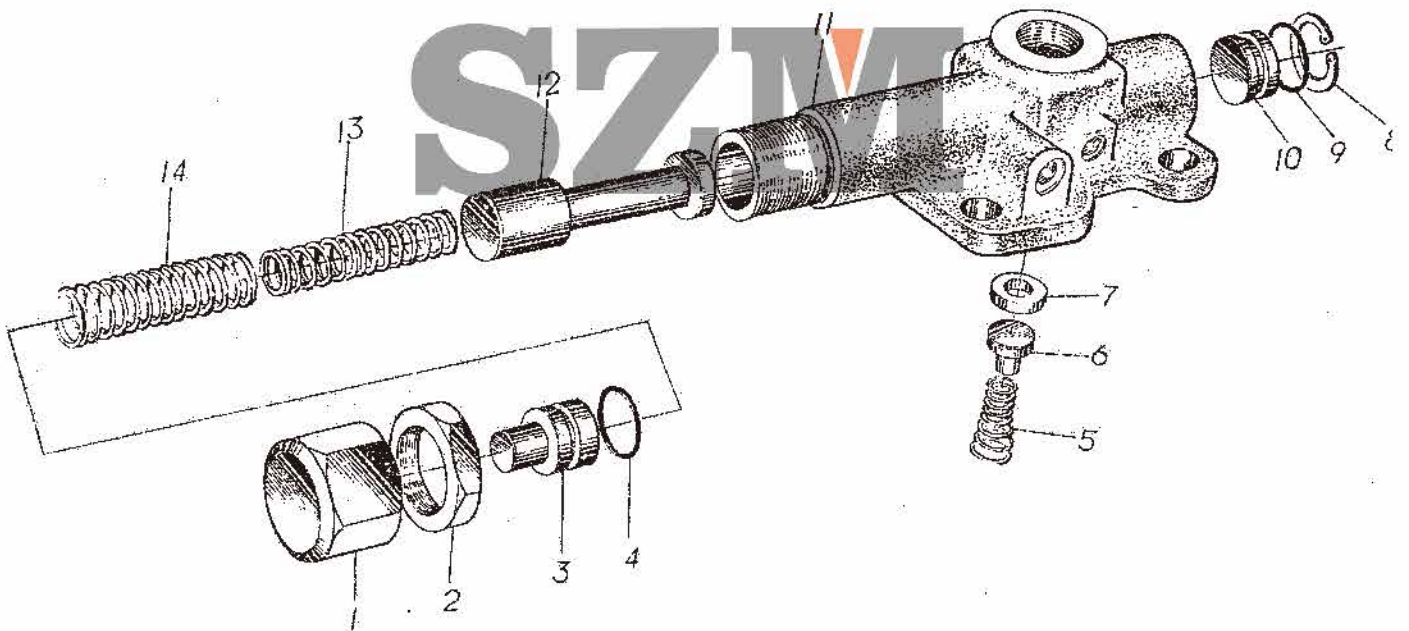

# 青州山装

序号 KEY	件号 PART NO.	名称 DESCRIPTION	数量 QTY
1		调节螺母	1
2		锁紧螺母	1
3		挡柱 II	1
4	GB3452.1-82	O型圈 15 × 2.65	1
5		锥形弹簧	1
6		阀芯 II	1
7		阀座	1
8	GB893.1-86	挡圈 20	1
9	GB3452.1-82	O型圈 14 × 2.65	1
10		挡柱 I	1
11		阀体	1
12		阀芯 I	1
13		小弹簧	1
14		大弹簧	1

# SZM

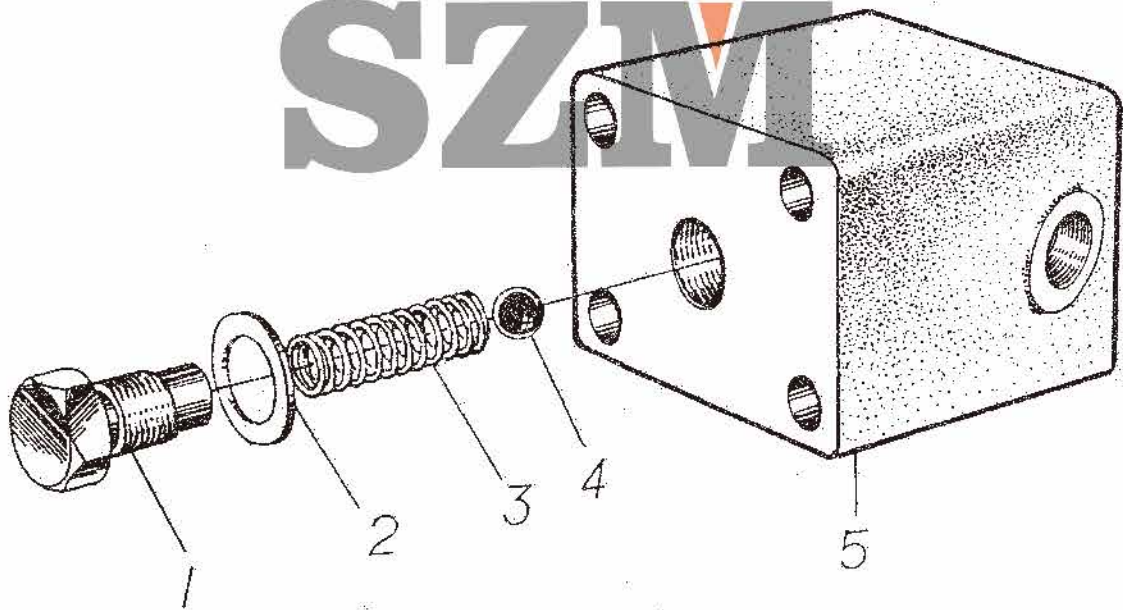

# 青州山装

序号 KEY	件号 PART NO.	名称 DESCRIPTION	数量 QTY
1		压紧螺钉 SCREW	1
2	J8982-77	组合垫圈 20 WASHER 20	1
3		弹簧 SPRING	1
4	GB308-84	钢球 $\phi$ 11 STEEL BALL $\phi$ 11	1
5		出口阀体 VALVE BODY	1

# SZMI



变速箱总成

TRANSMISSION ASSEMBLY

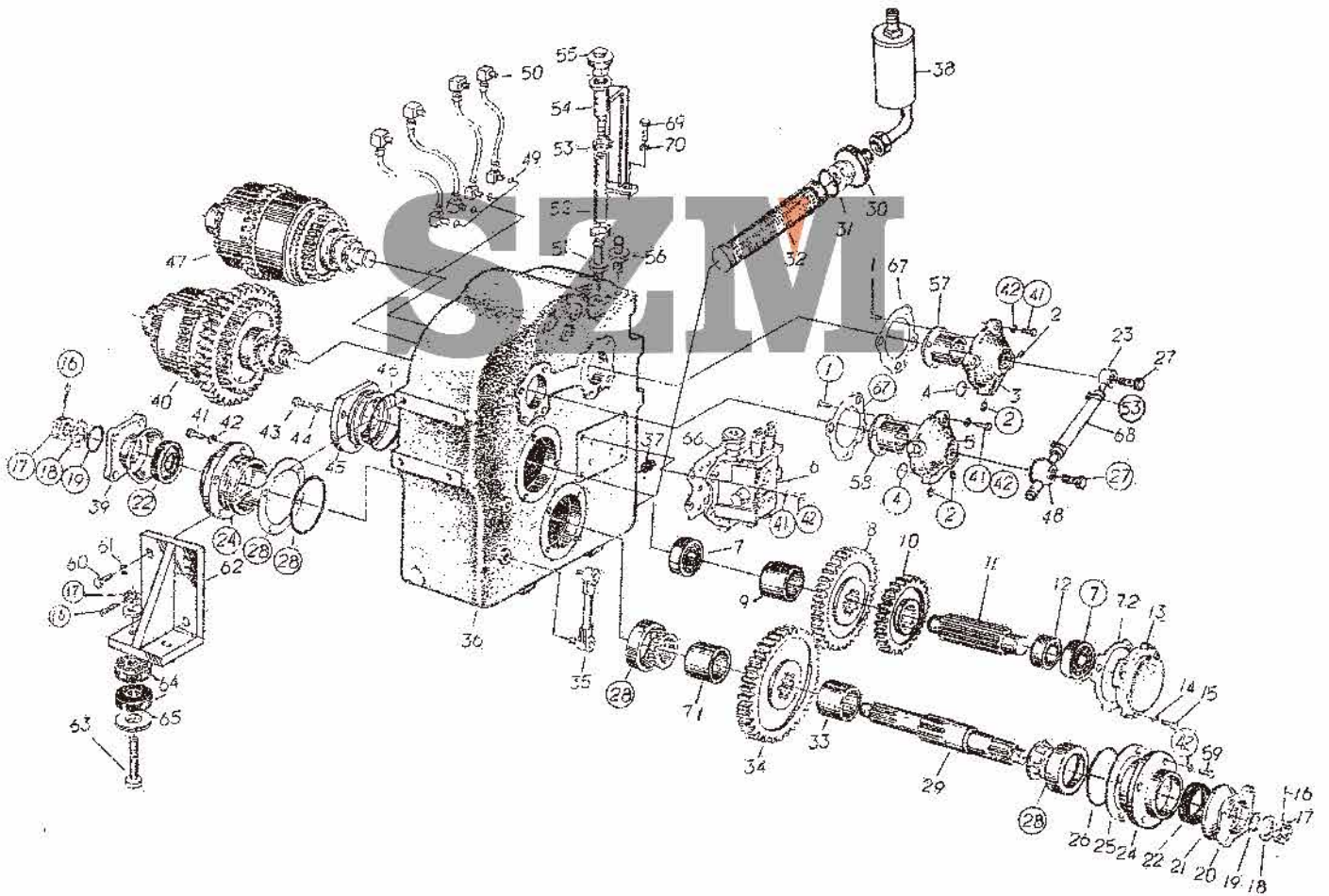

# 青州山装

序号 KEY	件号 PART NO.	名称 DESCRIPTION	数量 QTY
1	GB70-85	螺钉 M6 × 12	4
2		内六角螺塞	6
3		前进低档过油端盖	1
4		O型圈 10.6 × 2.65	4
5		倒退高档过油端盖	1
6		变速操纵阀	1
7	GB276-89	轴承 308	2
8		中间轴齿轮 II	1
9		中间轴垫圈 II (34)	1
10		中间轴齿轮 I	1
11		中间轴	1
12		中间轴垫圈 I (39.5)	1
13		中间轴前端盖	1
14	GB93-87	垫圈 12	8
15	GB5783-86	螺栓 M12 × 30	8
16	GB91-86	销 2.5 × 26	3
17		螺母 M20 × 1.5	2
18		垫圈	2
19	GB3452.1-82	O型圈 30 × 3.0	2
20		前输出法兰	1
21		防尘罩	2
22		油封总成 47 × 84 × 12.5	2
23		接头	1
24		轴承座	1
25		调整垫片	1
26	GB3452.1-82	O型圈 103 × 3.55	2
27		空心螺栓	2
28	GB297-84	轴承 7308E	2
29		输出轴	1
30		螺塞	1
31		O型圈 51.5 × 2.65	1
32		滤油网	1
33		输出轴垫圈 I	1
34		输出齿轮	1
35		油标	1
36		变速箱壳体	1
37		螺塞	1
38		滤油器	1
39		后输出法兰	1
40		后退档离合器总成	1
41	GB5783-86	螺栓 M12 × 40	4
42	GB93-87	垫圈 12	8
43	GB5783-86	螺栓 M10 × 30	12
44	GB93-87	垫圈 10	12
45		中间轴后端盖	1
46	GB3452.1-82	O型圈 82.5 × 3.55	1
47		前进档离合器总成	1
48		三通接头	1
49	GB3452.1-82	O型圈 10.6 × 2.65	8
50		油管总成	4
51		加油管接头	1
52		1" 低压耐油胶管	1
53	ZBJ15001-87	喉箍 d40	4
54		杯体	1
55		螺盖	1
56		透气塞	1
57		前进低档端盖衬套	1
58		倒退高档端盖衬套	1
59	GB5783-86	螺栓 M12 × 30	4
60	GB5783-86	螺栓 M20 × 35	8

变速箱总成

TRANSMISSION ASSEMBLY

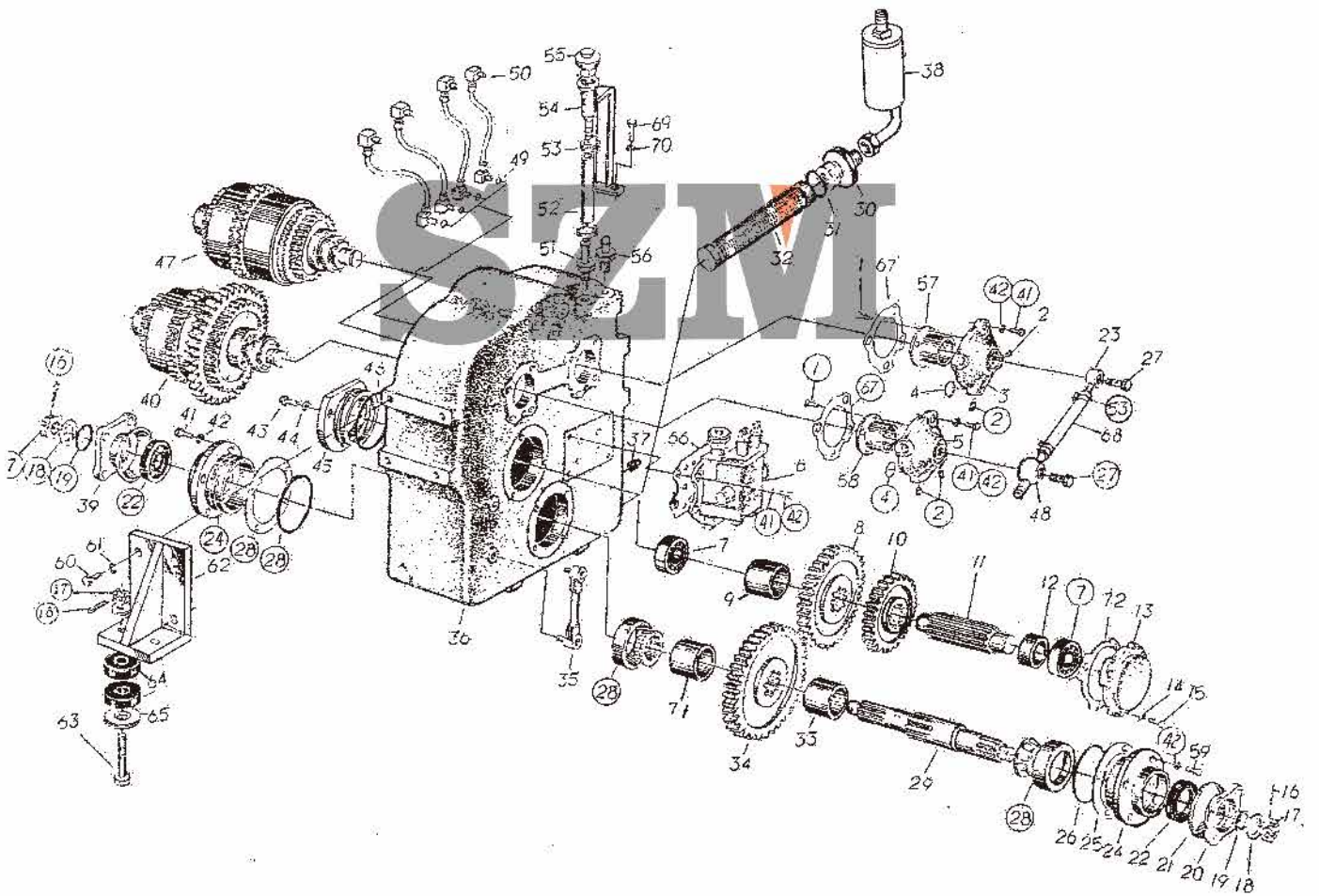



# 青州山装

序号 KEY	件号 PART NO.	名称 DESCRIPTION	数量 QTY
61	GB93-87	垫圈 20	8
62		变速箱支承座	1
63	GB31.1-88	螺栓 M20 × 80	4
64		变速箱支承轮垫	4
65		垫板	2
66		密封垫	1
67		密封垫	3
68		胶管	1
69	GB5783-86	螺栓 M8 × 20	2
70	GB93-87	垫圈 8	2
71		输出轴垫圈 II	1
72		密封垫	1

# SZM



前进低挡离合器总成

FRONT LOW CLUTCH ASSEMBLY

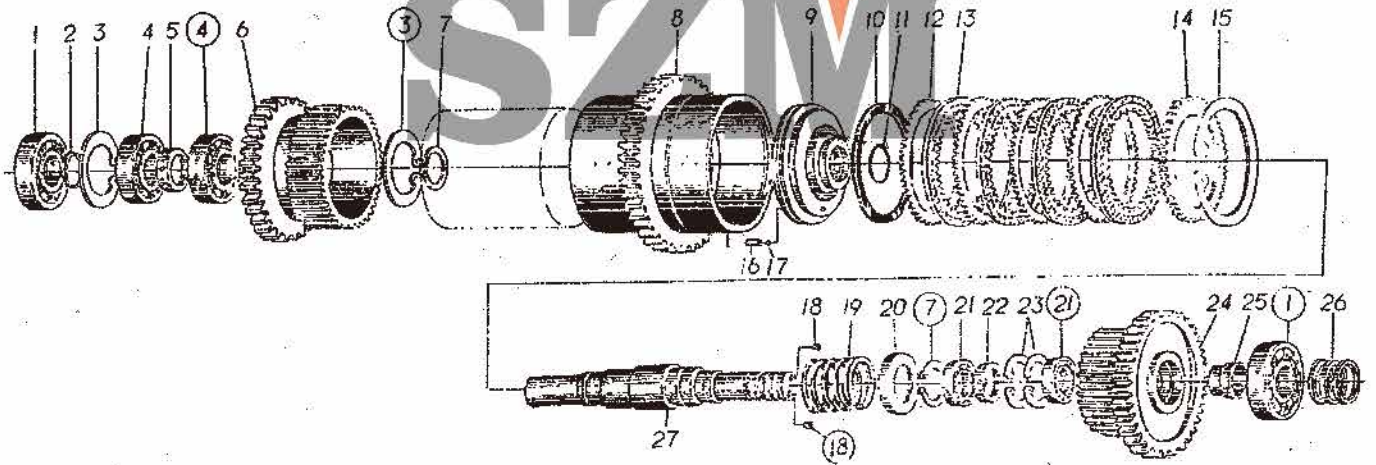

# 青州山装

序号 KEY	件号 PART NO.	名称 DESCRIPTION	数量 QTY
1	GB276-89	轴承 308	2
2		垫圈	1
3	GB894.1-86	垫圈 40	2
4	GB277-89	轴承 50208	1
5		挡圈	1
6		齿轮	1
7	GB305-89	止动环 80	1
8		前进低档离合器壳体	1
9		活塞	2
10		密封环	2
11		密封环	2
12		离合器被动片	8
13		离合器被动片	8
14		离合器主动片	2
15	GB893.1-86	挡圈 135	2
16		单向阀座	2
17	GB308-84	钢球 3/16"	2
18	Q/2B285-77	螺塞 2G1/8"	2
19		离合器弹簧	2
20		弹簧压板	2
21	GB276-89	轴承 108	2
22		挡圈	1
23	GB893.1-86	挡圈 68	2
24		齿轮	1
25		隔环	1
26		密封环	3
27		离合器轴	1



倒退高挡离合器总成

REVERSE CLUTCH ASSEMBLY

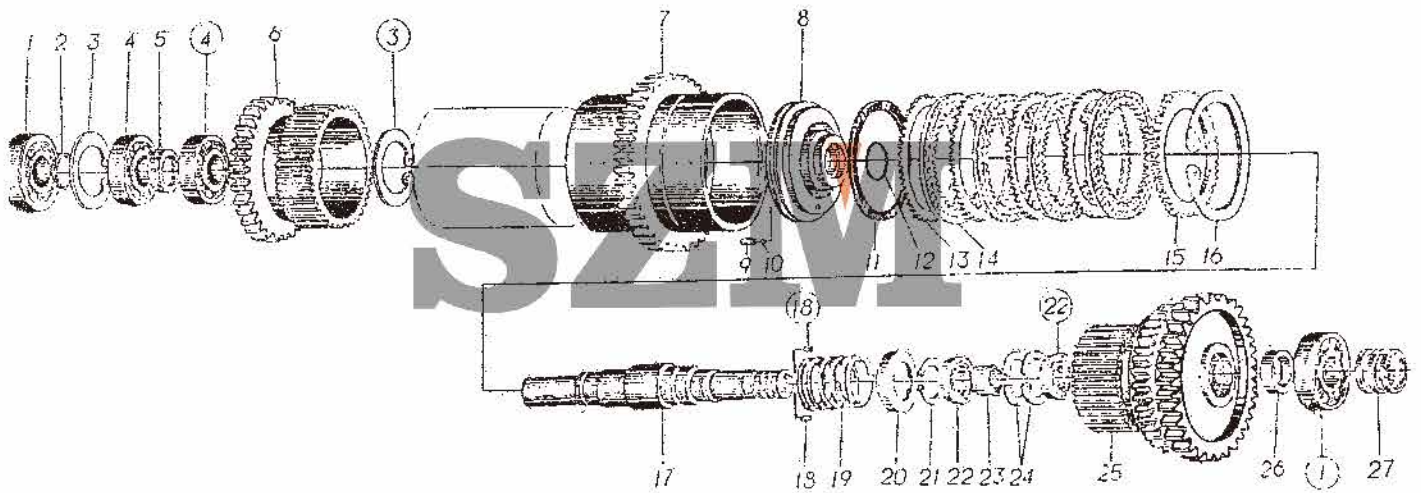

# 青州山装

序号 KEY	件号 PART NO.	名称 DESCRIPTION	数量 QTY	
1	GB276-89	轴承 308	BEARING 308	1
2		垫圈	WASHER	1
3	GB305-89	止动环 80	LOCK RING 80	1
4	GB277-89	轴承 50208	BEARING 50208	1
5		挡圈	SNAP RING	1
6		齿轮	GEAR	1
7		壳体	CLUTCH SUMP	1
8		活塞	PISTON	2
9		单向阀座	CHECK VALVE SEAT	2
10	GB308-84	钢球 3/16"	STEEL BALL	2
11		密封环	SEAL RING	2
12		密封环	SEAL RING	2
13		离合器被动片	CLUTCH DRIVEN DISC	8
14		离合器主动片	CLUTCH DRIVING DISC	8
15		离合器压板	CLUTCH CLAMPING PLATE	2
16	GB893.1-86	挡圈 135	SHAP RING 135	2
17		离合器轴	CLUTCH SHAFT	1
18	Q/ZB285-77	螺塞 2G 1/8"	THREAD PLUG 2G 1/8"	2
19		离合器弹簧	SPRING	2
20		弹簧压板	SPRING RETAINER	2
21	GB894.1-86	挡圈 40	SHAP RING 40	2
22	GB276-89	轴承 208	BEARING	4
23		隔环	SPACER	1
24	GB893.1-86	挡圈 80	SHAP RING 80	3
25		双联齿轮	GEAR	1
26		隔套	SLEEVE	1
27		密封环	SEAL RING	3

SZM



变速操纵阀

TRANSMISSION CONTROL VALVE

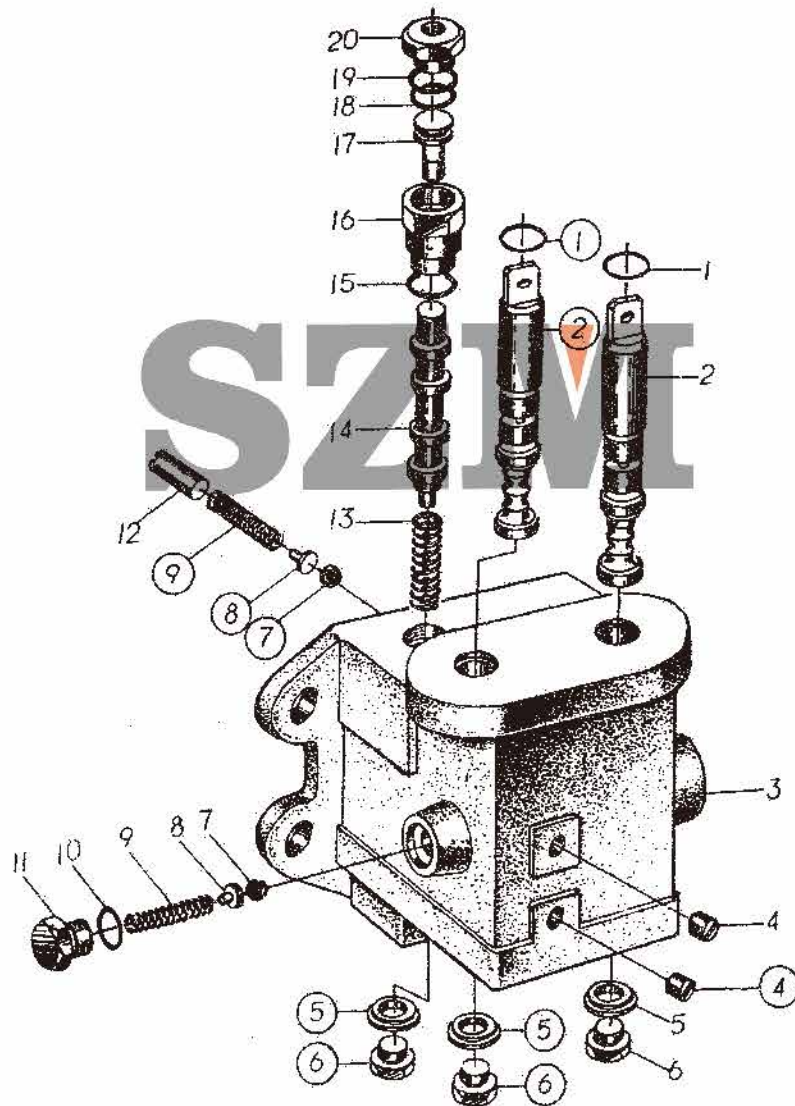

# 青州山装

序号 KEY	件号 PART NO.	名称 DESCRIPTION	数量 QTY
1	GB3452-82	O型圈	"O" RING 2
2		阀杆	VALVE STEM 2
3		阀体	VALVE BODY 1
4	Q/ZB285-77	螺塞	THREAD PLUG 2
5	JB982-77	垫圈	WASHER 3
6	JB1000-77	螺塞	THREAD PLUG 3
7	GB308-89	钢球	STEEL BALL 2
8		限位柱	STOPPER 2
9		弹簧	SPRING 2
10	GB3452.1-82	"O"型圈	"O" RING 1
11		螺塞	THREAD PLUG 1
12		螺钉	SCREW 1
13		弹簧	SPRING 1
14		联动阀杆	DRIVE STERN 1
15	GB3452.1-82	O型圈	"O" RING 1
16		气阀体	AIR VALVE BODY 1
17		气阀杆	AIR VALVE STEM 1
18	GB3452.1-82	O型圈	"O" RING 1
19	GB3452.1-82	O型圈	"O" RING 1
20		接头	CONNECTOR 1

# SZM

变速操纵机构

GEAR SHIFT CONTROL ASSEMBLY

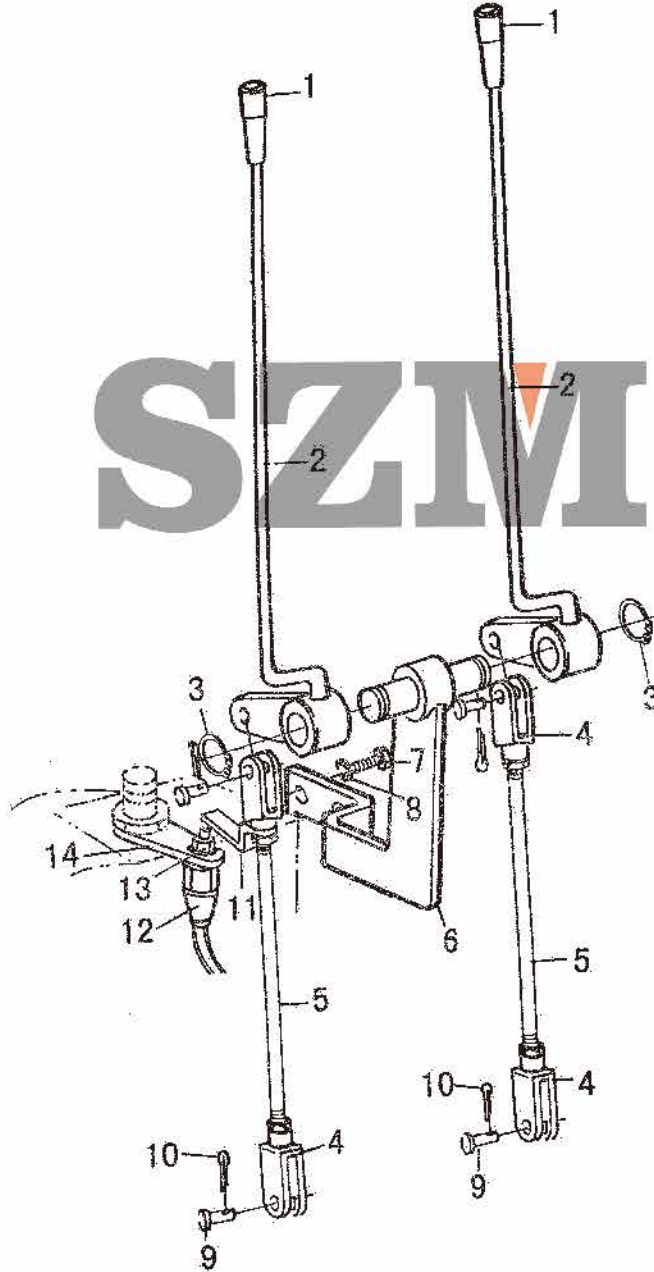

# 青州山装

序号 KEY	件号 PART NO.	名称 DESCRIPTION		数量 QTY
1		变速操纵手球	OPERATION HANDLE	2
2		档位操纵杆组件	SHIFTING LEVER	2
3	GB894.1-86	挡圈 14	SNAP RING 14	2
4		拉叉	YOKE	4
5		拉杆	ROD	2
6		档位操纵支架组件	SUPPORT	1
7	GB/T5783-2000	螺栓 M10 × 30	BOLT M10 × 30	2
8	GB/T93-1987	垫圈 10	WASHER 10	2
9		销子 8 × 30	PIN 8 × 30	4
10	GB/T91-2000	开口销 2.8	SPLIT PIN 2.8	4
11		倒档开关压板	PLATES	1
12		倒档开关	REVERSE SWITCH	1
13	GB/T6170-2000	螺母 M8	NUT M8	4
14		支架	SUPPORT	1

# SZM



传动液压系统

TRANSMISSION HYDRAVLIC SYSTEM

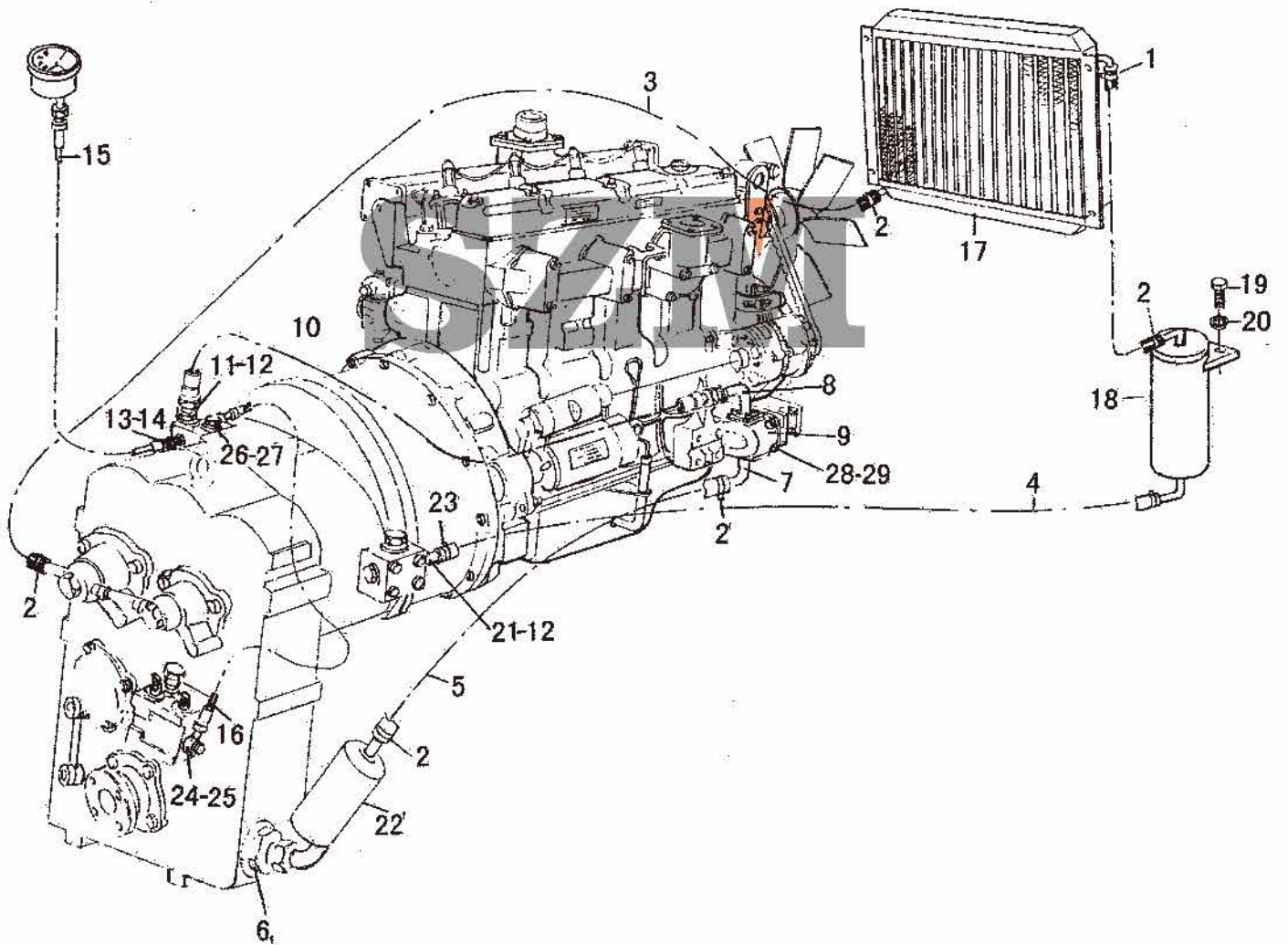

# 青州山装

序号 KEY	件号 PART NO.	名称 DESCRIPTION	数量 QTY
1		散热器到滤清器低压管	1
2	JB/T8870-1999	喉箍 32-44	6
3		变速箱到散热器低压管	1
4		变矩器回油低压管	1
5		行走泵进油管	1
6		变速箱出油接头	1
7		行走泵进油接头组件	1
8		行走泵出油接头组件	1
9		行走泵	1
10		行走泵到减压阀油管	1
11		减压接头 I	1
12		铜垫 27	1
13		压力表接头	1
14		铜垫 10	1
15		压力表油管	1
16		减压阀到分配阀油管	1
17		机油散热器	1
18		滤清器	1
19	GB/T5783-2000	螺栓 M8 × 30	2
20	GB/T93-1987	垫圈 8	10
21		变矩器回油接头	1
22		滤网	1
23	JB/T8870-1999	喉箍 22-32	2
24		分配阀接头	1
25		铜垫 14	1
26		减压阀接头 II	1
27		铜垫 18	1
28	GB/T5783-2000	螺栓 M8 × 20	8
29		O型圈 24	2

滤油器总成

OIL FILTER ASSEMBLY

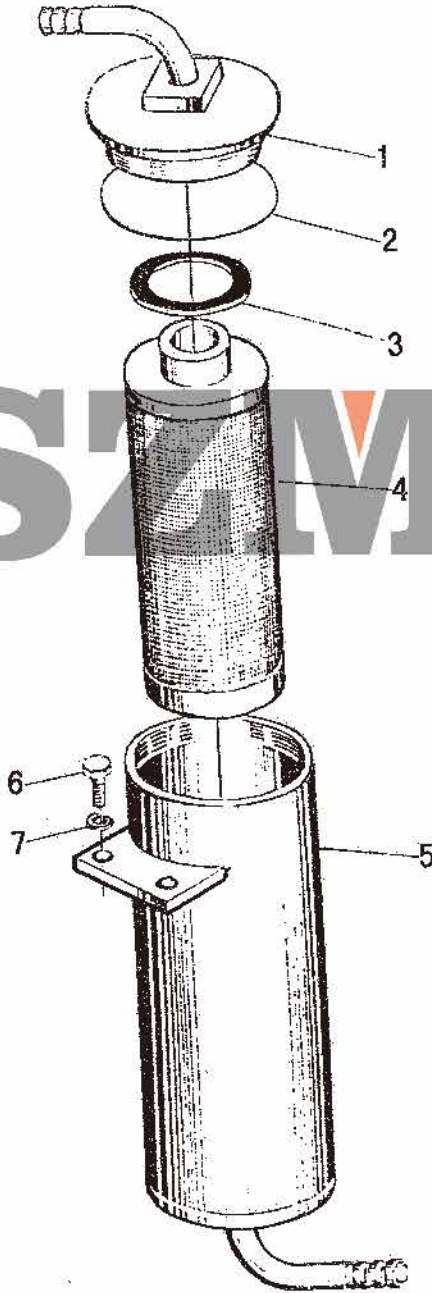

# 青州山装

序号 KEY	件号 PART NO.	名称 DESCRIPTION	数量 QTY
1		出油口接头总成	1
2		"O" 密封圈 145 × 5.7	1
3		胶垫	1
4		滤网芯	1
5		外壳总成	1
6		螺栓 M8 × 20	6
7		垫圈 8	6

# SZM



驱动桥总成

AXLE ASSEMBLY

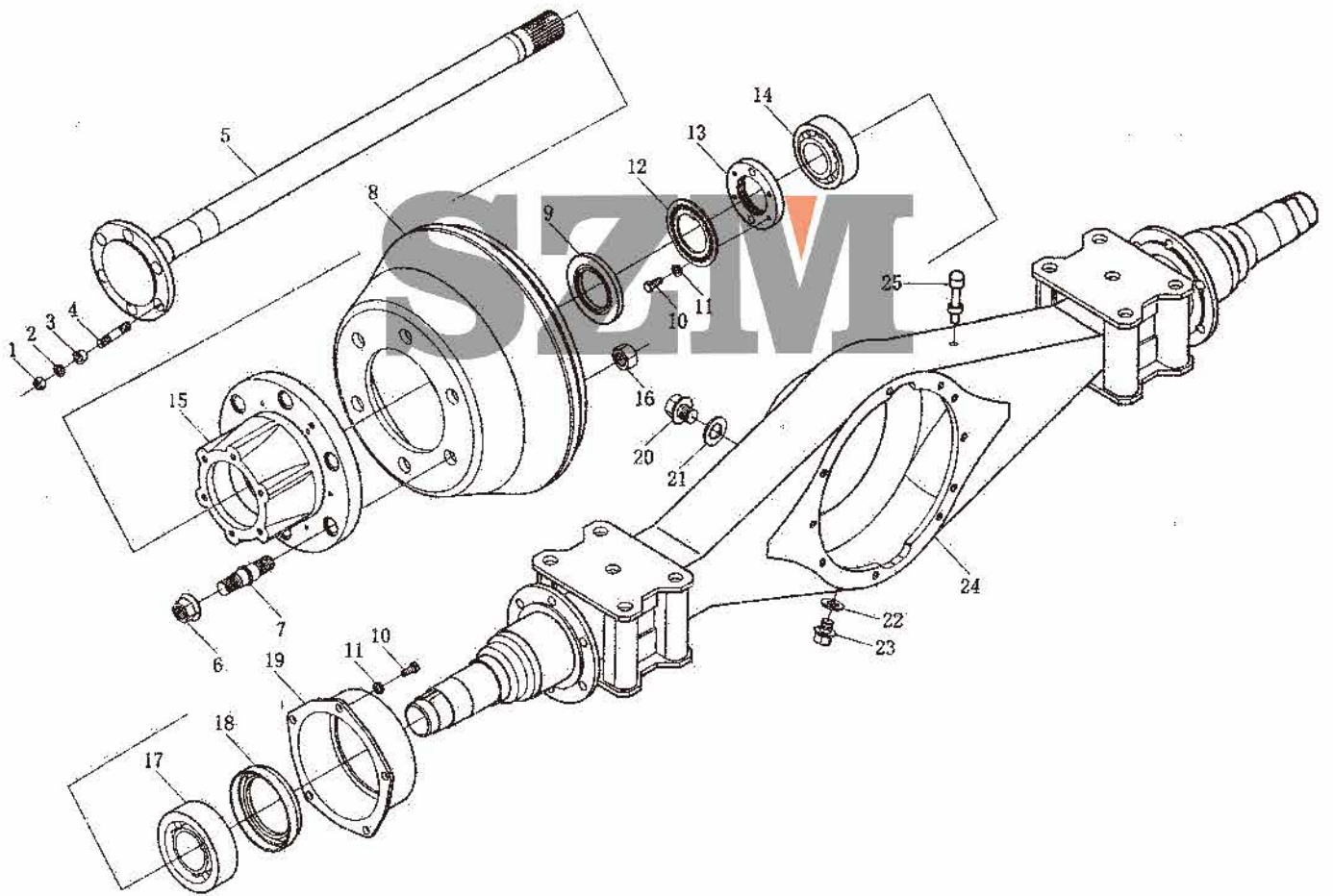

# 青州山装

序号 KEY	件号 PART NO.	名称 DESCRIPTION	数量 QTY
1		I型六角螺母-细牙 M10 × 1.25	12
2		弹簧垫圈	12
3		特种垫圈	12
4		双头螺柱	12
5		后桥半轴	2
6		轮毂螺母 (左/右)	12
7		轮毂螺栓 (左/右)	12
8		制动鼓	2
9		后轮毂外油封	2
10		六角头螺栓和弹簧垫圈组合件	2
		六角头螺栓 M6 × 10	12
11		弹簧垫圈	12
12		锁止垫圈 (后轮毂轴承)	2
13		螺母 (后轮毂轴承)	2
14		后轮毂外轴承	2
15		后轮毂	2
16		轮毂内螺母 M18 × 1.5	12
17		后轮毂内轴承	2
18		后轮毂内油封	2
19		挡油盘	2
20		加油塞	2
21		注油塞垫圈	1
22		放油塞垫圈	1
23		放油螺塞	1
24		后桥壳总成	1
25		常闭式通气塞	1

SZM

主传动总成

MAIN REDUCER ASSEMBLY

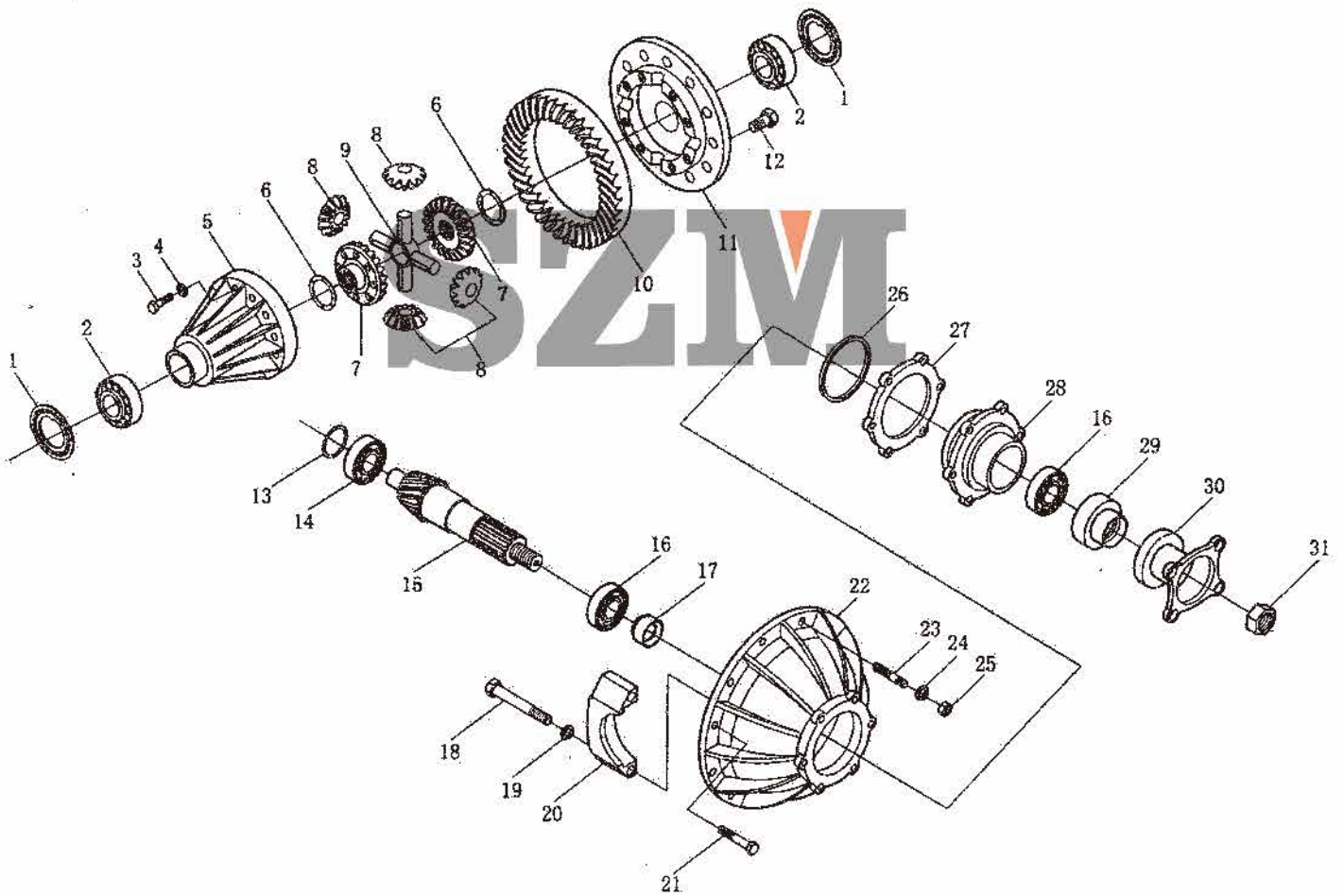

# 青州山装

序号 KEY	件号 PART NO.	名称 DESCRIPTION	数量 QTY	
1		调整螺母	ADJUSTING NUT	2
2		差速器轴承	BEARING	2
3		螺栓 (差速器壳体)	BOLT	12
4		差速器壳体垫圈	WASHER	25
5		差速器壳 (右)	LEFT CASE,DIFFERENTIAL	1
6		半轴齿轮止推垫片	SHM	2
7		半轴齿轮	SPIDER GEAR	2
8		行星齿轮	PLANET GEAR	4
9		行星齿轮轴	CAREDN SHAFT	1
10		被动齿轮	SPIRAL BEVEL GEAR	1
11		差速器壳 (左)	LEFT CASE,DIFFERENTIAL	1
12		螺栓 (从动齿轮)	BOLT	12
13		导向轴承弹簧挡圈	SNAP RING	1
14		主动齿轮导向轴承	BEARING	1
15		主动齿轮	SPIRAL BEYE PINION	1
16		主动齿轮轴承	BEARING	2
17		轴承隔套	ISOLATOR	1
18		六角头螺栓	BOLT	4
19		弹簧垫圈	WASHER	4
20		轴承盖 (主减速器)	BEARING COVER	2
21		螺栓 (桥壳, 主减速器)	BOLT	7
		螺栓 (桥壳, 主减速器)	BOLT	4
22		主减速器壳	MAIN REDUCER CASE	1
23		双头螺栓 (桥壳, 主减速器)	STUD	2
24		弹簧垫圈	WASHER	13
25		六角头螺母	NUT	2
26		O型圈 (轴承座)	O-RING	1
27		调整垫片	LOCK PLATE	5
28		主动齿轮轴承座	BEARING SEAT	1
29		主动齿轮油封	SEAL RING	1
30		主动齿轮法兰盖总成	FLANGE ASS' Y	1
31		主动齿轮自锁螺母	LOCK NUT	1



后传动轴  
REAR DRIVING SHAFT

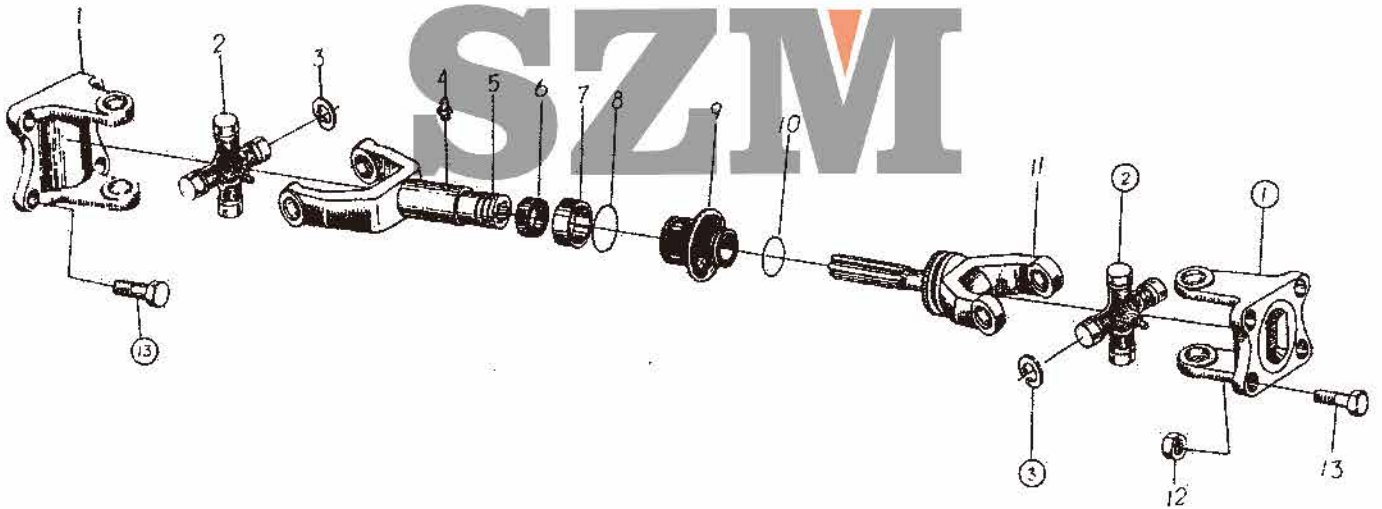

# 青州山装

序号 KEY	件号 PART NO.	名称 DESCRIPTION	数量 QTY
1		突缘叉	2
2		方向节总成	2
3		卡簧	8
4	GB1152-89	油杯 M10 × 1	1
5		短滑动叉总成	1
6		橡胶油封	1
7		滑动叉防尘盖	1
8		大卡环	1
9		防尘套	1
10		小卡环	1
11		花键轴总成	1
12	GB889-80	螺母 M14 × 2.5	4
13		螺栓	8

# SZM

前传动轴

FRONT DRIVING SHAFT

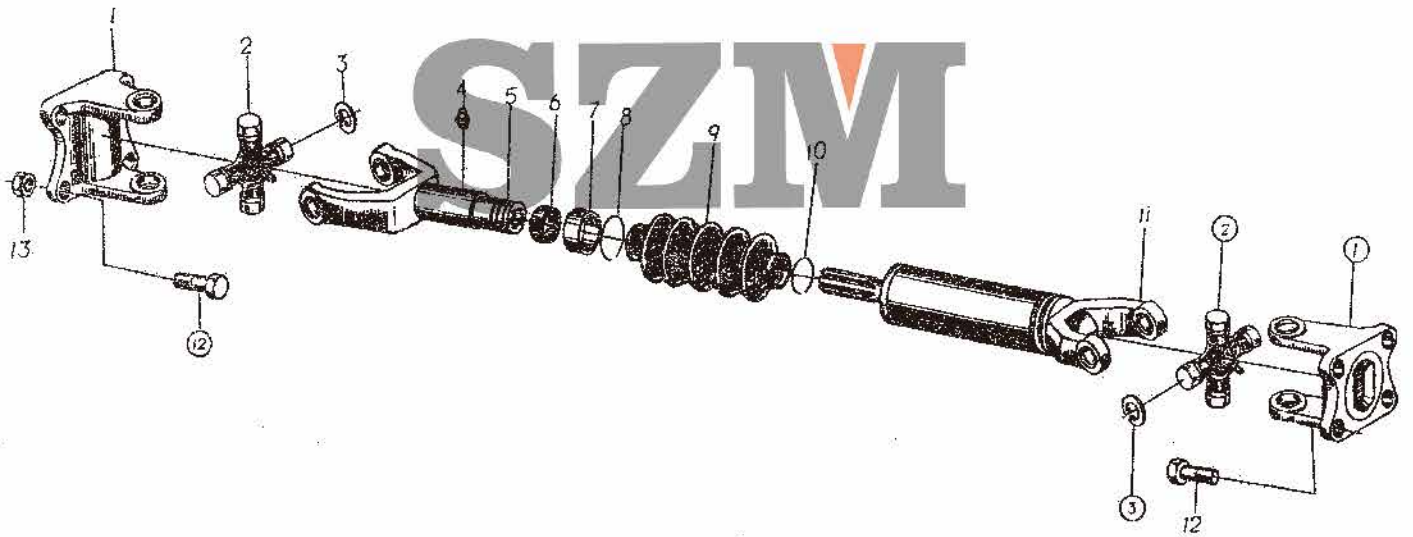

# 青州山装

序号 KEY	件号 PART NO.	名称 DESCRIPTION	数量 QTY
1		突缘叉	2
2		方向节总成	2
3		卡簧	8
4	GB1152-89	油杯 M10 × 1	1
5		短滑动叉总成	1
6		橡胶油封	1
7		滑动叉油封盖	1
8		大卡环	1
9		防尘套	1
10		小卡环	1
11		花键轴总成	1
12		螺栓	8
13	GB889-80	螺母 M14 × 1.5	4

# SZM

轮胎、轮辋总成

TYRE RIM MODULE





# 青州山装

序号 KEY	件号 PART NO.	名称 DESCRIPTION	数量 QTY
1		轮辋体 RIM	1
2	11.00-16	轮胎 TIKE ASS' Y	1
3		外轮缘 BAND	1
4		锁环 RING LOCK	1

# SZMI

制动液压系统

BRAKE HG DRAULIC SYSTEM

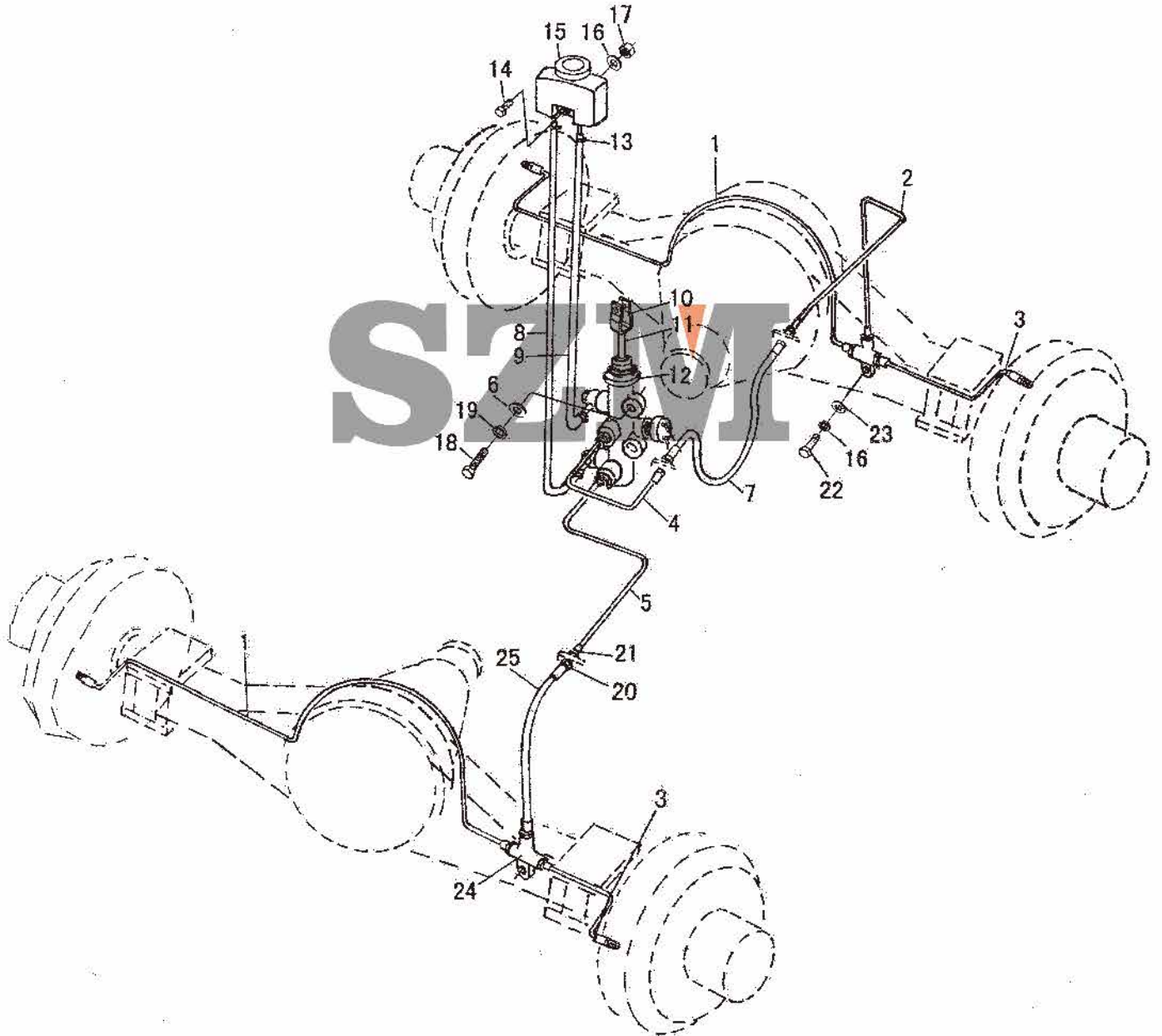

# 青州山装

序号 KEY	件号 PART NO.	名称 DESCRIPTION	数量 QTY
1		刹车铜管 I	2
2		刹车铜管 II	1
3		刹车铜管 III	2
4		刹车铜管 IV	1
5		刹车铜管 V	1
6	GB/T97.1-2000	垫圈 10	1
7		刹车软管 I	1
8		刹车泵软管 I	1
9		刹车泵软管 II	1
10		拉叉	1
11		制动拉杆	1
12		制动泵	1
13	JB/T8870-1999	喉箍 10-16	4
14	GB/T5783-2000	螺栓 M8 × 25	1
15		刹车油壶	1
16	GB/T93-1987	垫圈 8	3
17	GB/T6170-2000	螺母 M8	1
18	GB/T5783-2000	螺栓 M10 × 60	2
19	GB/T93-1987	垫圈 10	2
20	GB/T97.1-2000	垫圈 16	3
21		刹车油路螺母	3
22	GB/T5783-2000	螺栓 M8 × 30	2
23	GB/T97.1-2000	垫圈 8	2
24		铜三通	2
25		刹车软管 II	1

**SZM**

制动泵总成

BRAKE PUMP ASSEMBLY

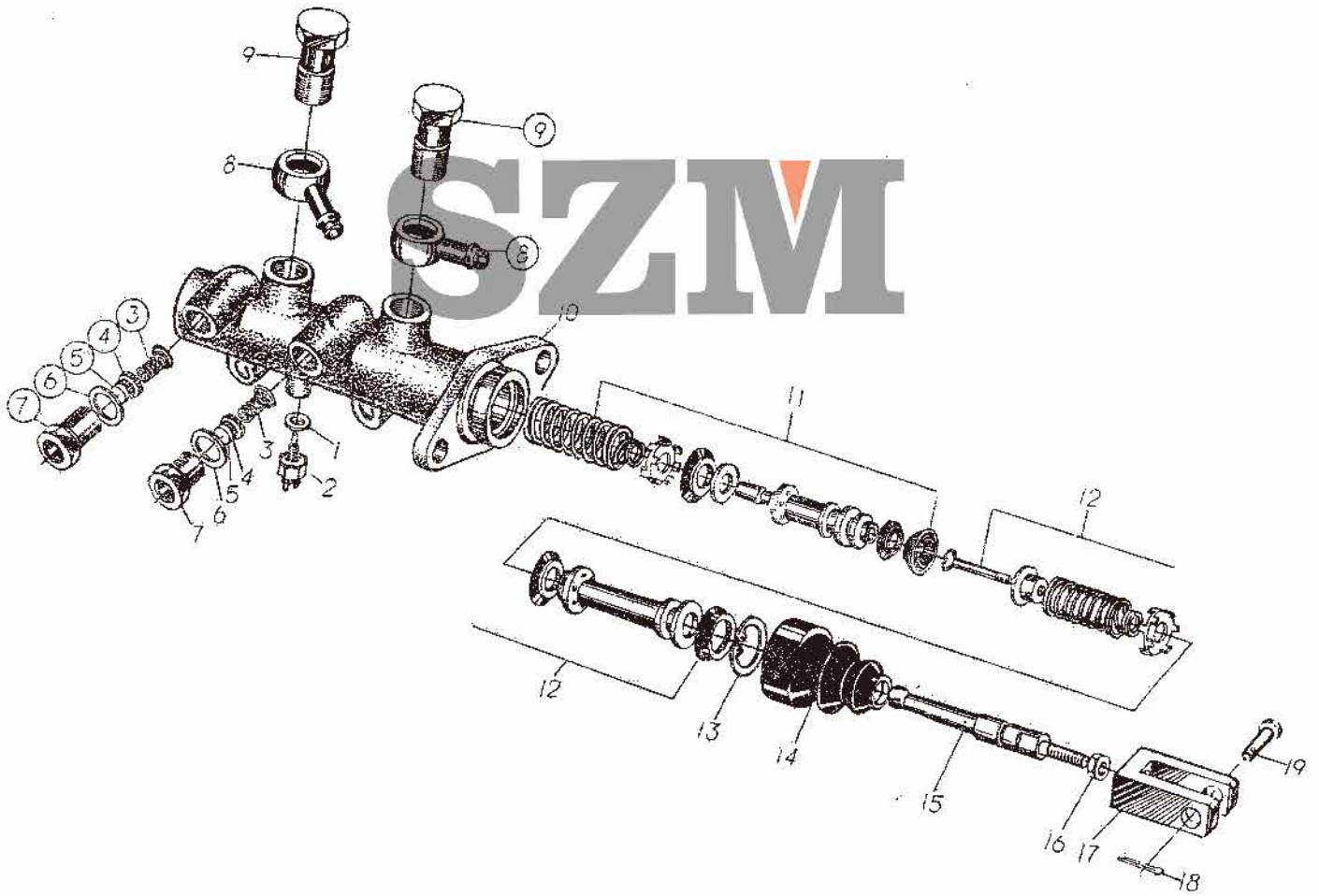

# 青州山装

序号 KEY	件号 PART NO.	名称 DESCRIPTION	数量 QTY
1		限位螺钉垫圈	1
2		刹车开关	1
3		输液阀弹簧	2
4		输液阀阀体	2
5		输液阀	2
6		输液阀垫圈	2
7		输液阀座	2
8		胶管座	2
9		连接螺栓	2
10		制动总泵缸体	1
11		前活塞总成	1
12		后活塞总成	1
13		卡圈	1
14		防尘罩	1
15		调整杆	1
16		螺母 M8	1
17		调整叉	1
18		开口销 3.2 × 20	1
19		螺栓 B10 × 26	1

# SZM



手制动操纵机构

BRAKE CONTROL MECHANISM

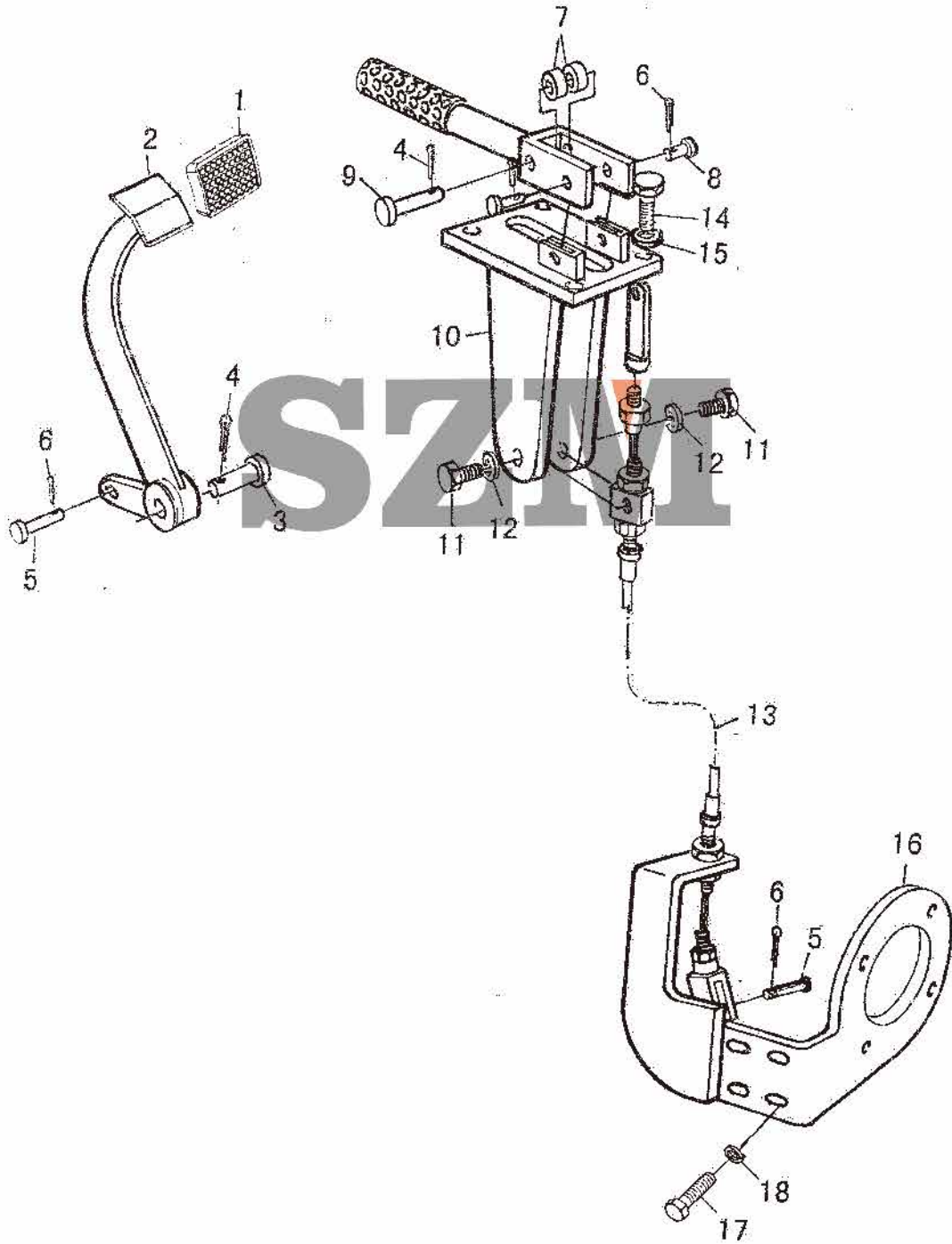

# 青州山装

序号 KEY	件号 PART NO.	名称 DESCRIPTION	数量 QTY	
1		防滑胶套	RUBBER PEDAL	1
2		刹车踏板	BRAKE PEDAL	1
3		销轴	PIN	1
4	GB/T91-2000	开口销 3.2	SPLIT PIN 3.2	2
5		销子 $\phi 8 \times 30$	PIN $\phi 8 \times 30$	2
6	GB/T91-2000	开口销 2	SPLIT PIN 2	4
7		套	BUSHING	2
8		短销 $\phi 10 \times 25$	PIN $\phi 10 \times 25$	2
9		长销 $\phi 10 \times 55$	PIN $\phi 10 \times 55$	1
10		手刹操纵座	MOUNTING SEAT	1
11		螺栓	BOLT	2
12		垫圈	WASHER	2
13		手刹线	CABLE SHAFT	1
14	GB/T5783-2000	螺栓 M8 $\times$ 25	BOLT M8 $\times$ 25	4
15	GB/T93-1987	垫圈 8	WASHER 8	4
16		手刹支架	SUPPORTING PLATE	1
17	GB/T5783-2000	螺栓 M12 $\times$ 30	BOLT M12 $\times$ 30	4
18	GB/T93-1987	垫圈 12	WASHER 12	4

# SZM

手制动器总成

HAND BRAKE ASSEMBLY

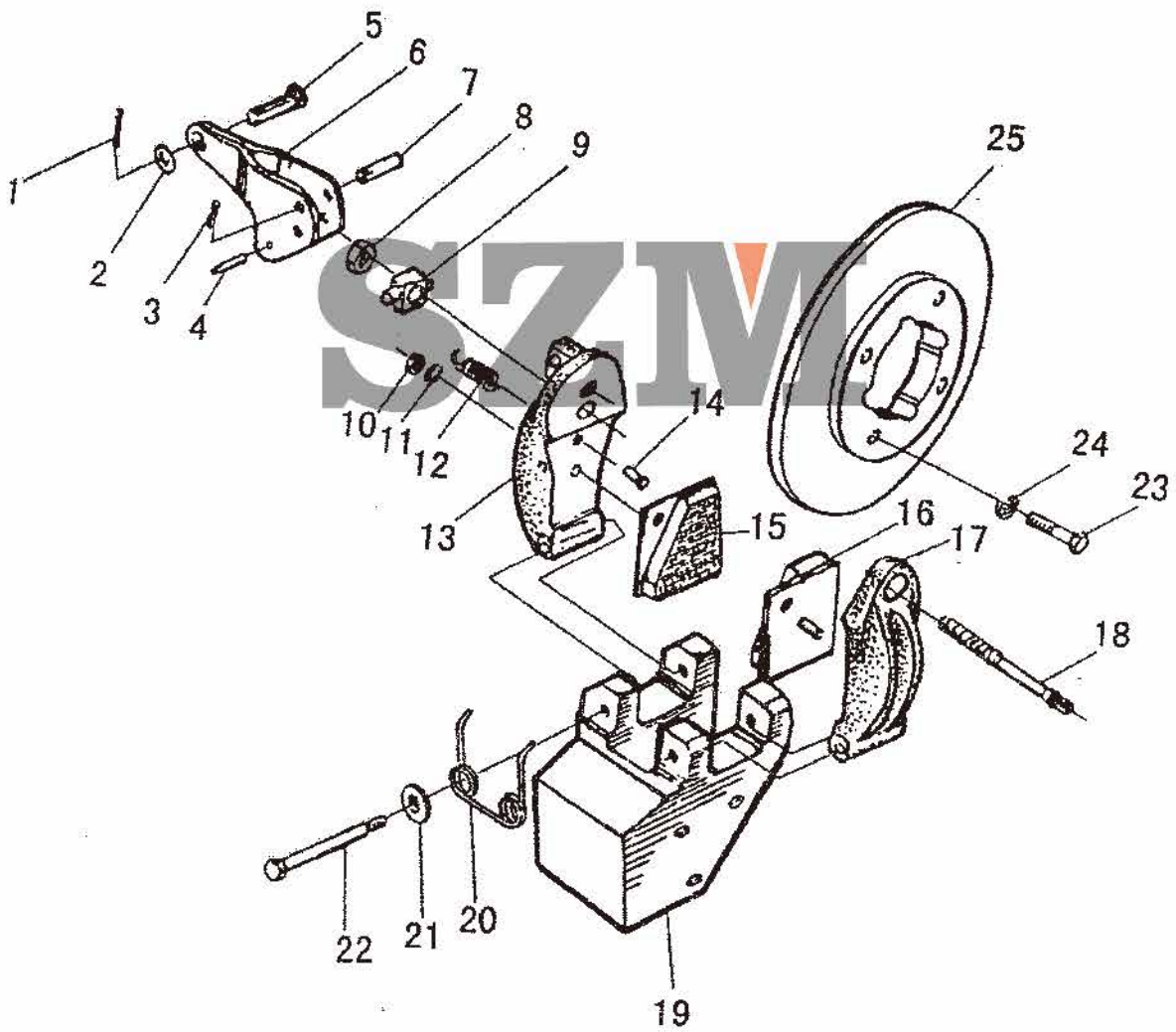

# 青州山装

序号 KEY	件号 PART NO.	名称 DESCRIPTION	数量 QTY	
1		开口销 3 × 20	SPLIT PIN 3 × 20	1
2		垫圈 10	WASHER 10	1
3		开口销 1.5 × 10	SPLIT PIN 1.5 × 10	1
4		销轴 4 × 22	PIN 4 × 22	1
5		销轴	PIN	1
6		制动曲柄	BRAKE CRANK	1
7		销轴	PIN	1
8		螺母 M10	NUT M10	1
9		支座	PEDESTAL	1
10		螺母 M5	NUT M5	2
11		垫圈 5	WASHER 5	2
12		拉簧	TENSION SPRING	1
13		主夹钳	MAIN CLAMP	1
14		弹簧拉销	SPRING PIN	1
15		主摩擦片	MAIN FRICTION BLOCK	1
16		副摩擦片	SECOND FRICTION BLOCK	1
17		副夹钳	SECOND CLAMP	1
18		拉杆螺栓	LIN KAGE BOLT	1
19		支座	PEDESTAL	1
20		复位弹簧	RETRACTION SPRING	1
21		垫圈	WASHER	2
22		螺栓	BOLT	2
23		螺栓	BOLT	4
24		垫圈	WASHER	4
25		制动盘	BRAKE DISC	1

# SZM

前车架总成  
FRONT FRAME

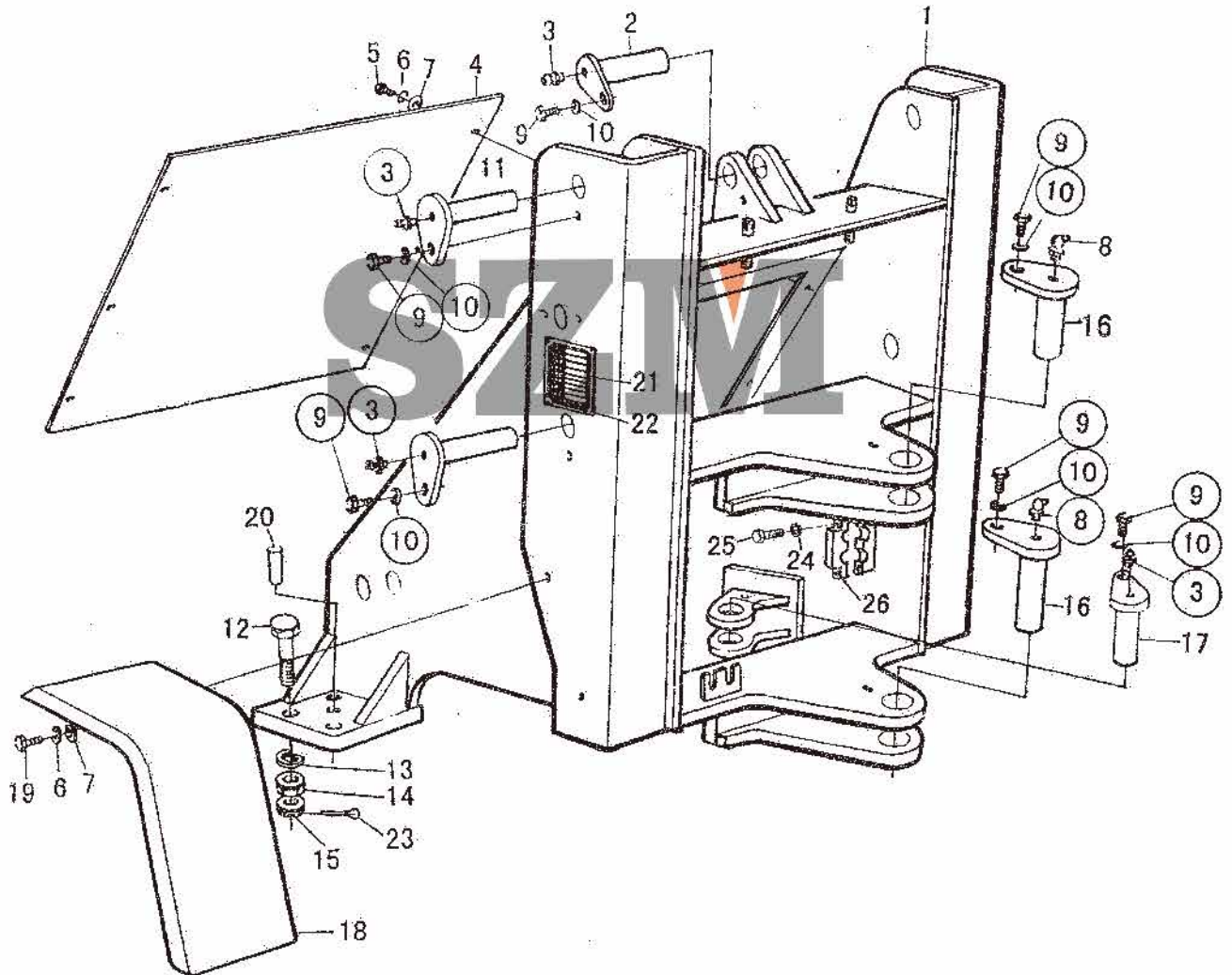



# 青州山装

序号 KEY	件号 PART NO.	名称 DESCRIPTION	数量 QTY
1		前车架	1
2		翻斗缸销轴	1
3	JB/T7940.1-1995	油杯 M8 × 1	3
4		前盖板	1
5	GB/T5783-2000	螺栓 M8 × 15	6
6	GB/T93-1987	垫圈 8	10
7	GB/T97.1-2002	垫圈 8	10
8	GB/T7940.1-1995	油杯 M8 × 1	4
9	GB/T5783-2000	螺栓 M10 × 20	7
10	GB/T93-1987	垫圈 10	7
11		前车架与动臂铰接销轴	4
12	GB/T5782-2000	螺栓 M16 × 190	8
13	GB/T93-1987	垫圈 16	8
14	GB/T6170-2000	螺母 M16	8
15	GB/T6178-1986	花螺母 M16	8
16		前、后车架铰接销轴	2
17		转向缸铰接销轴	1
18		前挡泥瓦	2
19	GB/T5783-2000	螺栓 M8 × 20	4
20		定位销	4
21		铭牌	1
22	GB/T827-1986	铆钉 3 × 5	4
23	GB/T91-2000	销 1.6 × 40	4
24	GB/T93-1987	垫圈 8	2
25	GB/T5783-2000	螺栓 M8 × 25	2
26		油管卡 (1)	1

SZM

后车架总成  
REAR FRAME

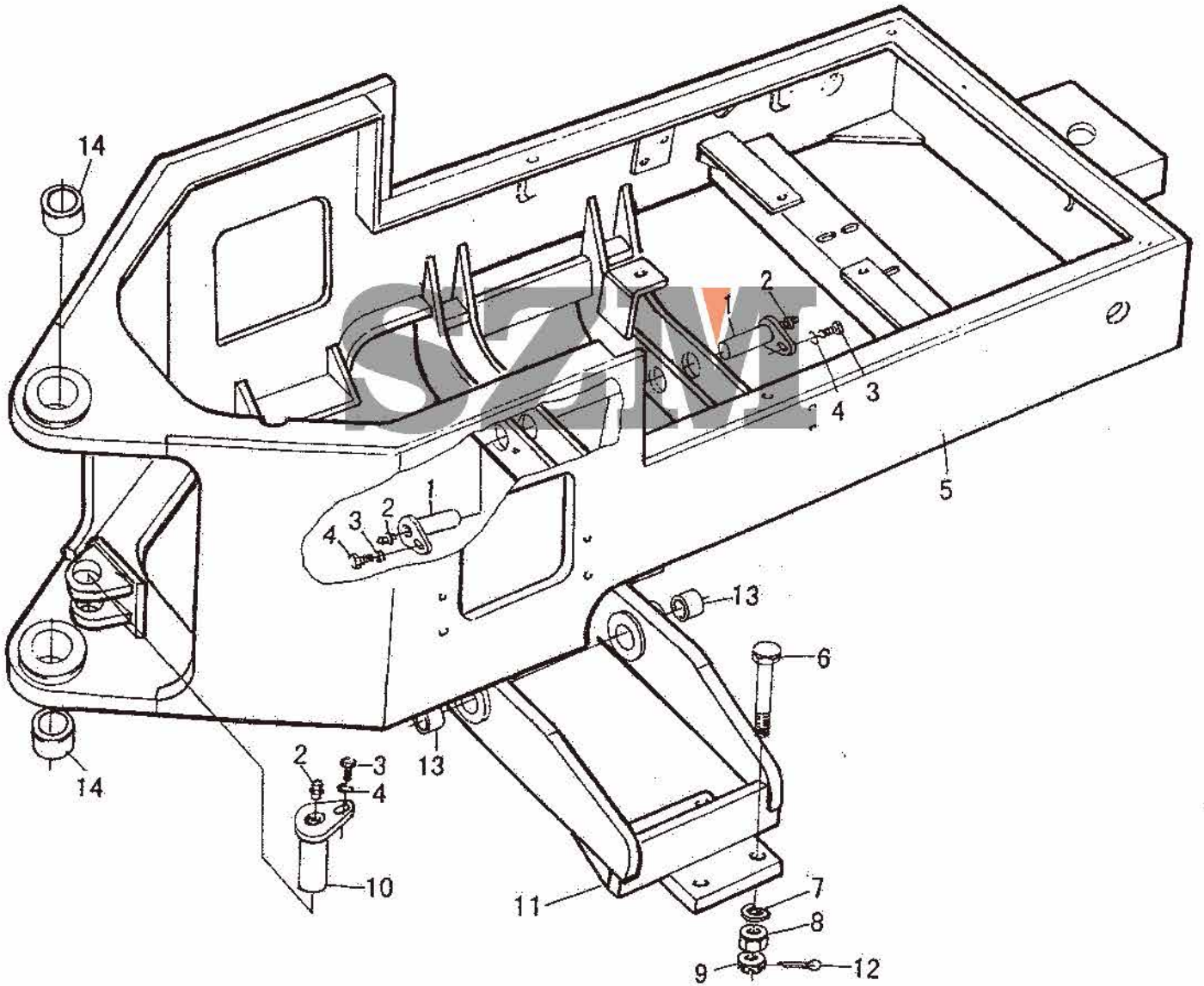

# 青州山装

序号 KEY	件号 PART NO.	名称 DESCRIPTION	数量 QTY
1		后车架与摆架铰接销轴	PIN SHAFT 2
2	GB/T7940.1-1995	油杯 M8 × 1	GREASE NIPPLE M8 × 1 3
3	GB/T5783-2000	螺栓 M10 × 20	BOLT M10 × 20 3
4	GB/T97-1983	垫圈 10	WASHER 16 3
5		后车架	REAR FRAME 1
6	GB/T5782-2000	螺栓 M16 × 190	BOLT M16 × 190 8
7	GB/T93-1987	垫圈 16	WASHER 16 8
8	GB/T6170-2000	螺母 M16	NUT M16 8
9	GB/T6178-1988	花螺母 M16	NUT M16 8
10		前、后车架与转向缸铰接销轴	PIN SHAFT 1
11		下摆架	LOWER OSILLATING FRAME 1
12	GB/T91-2000	开口销 1.6	PIVET 1.6 8
13		钢套 V	V SLEEVE 2
14		钢套 IV	IV SLEEVE 2

# SZM

铲斗总成

BUCKET ASSEMBLY

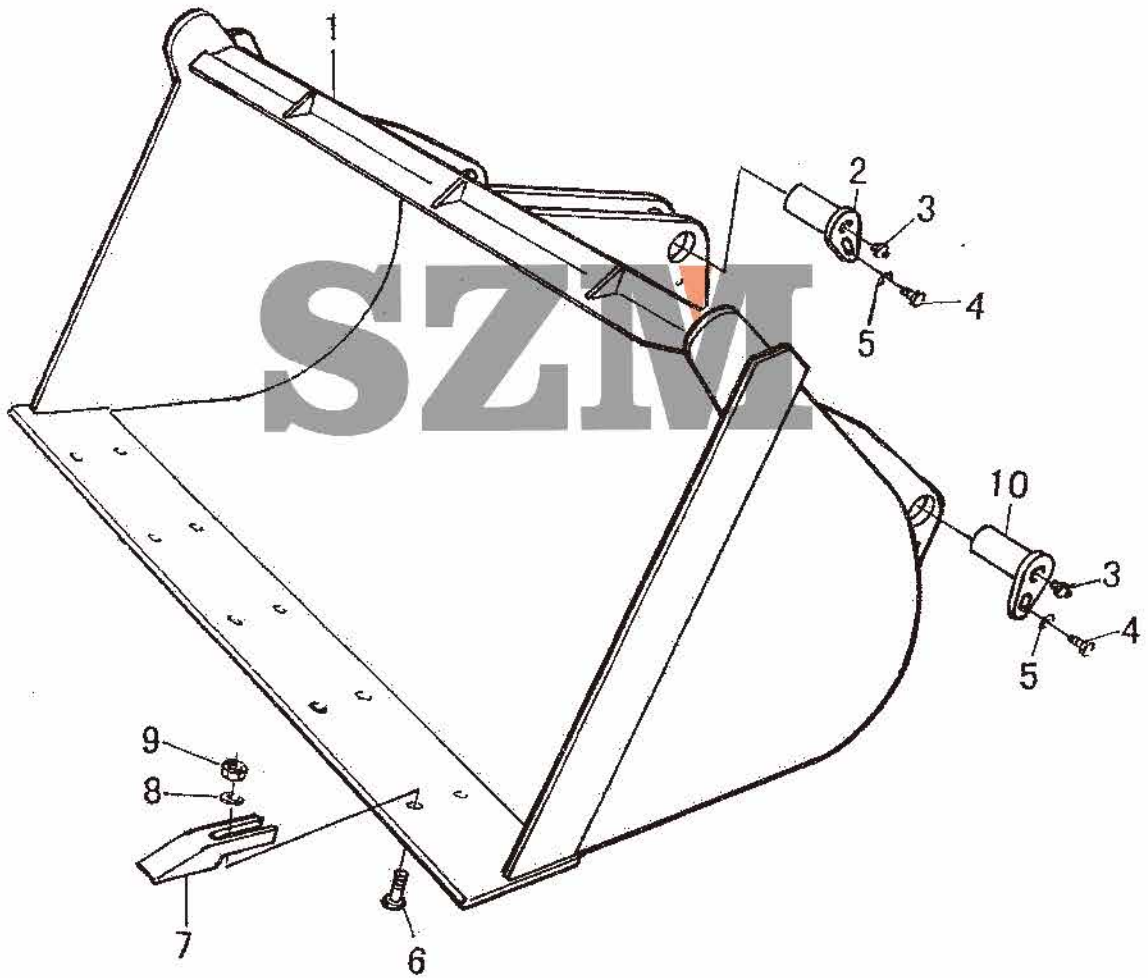

# 青州山装

序号 KEY	件号 PART NO.	名称 DESCRIPTION	数量 QTY
1		铲斗组件	1
2		铲斗与拉杆铰接轴	1
3	GB/T68-2000	油杯 M8 × 1	8
4	GB/5783-2002	螺栓 M10 × 20	2
5	GB/T93-1987	垫圈 10	2
6	GB/T97.1-2002	螺栓 M16 × 45	2
7		铲斗齿	5
8	GB/T93-1987	垫圈 16	2
9	GB/T6170-2000	螺母 M16	2
10		铲斗与动臂铰接销轴	2

# SZM



工作装置总成

WORKING EQUIPMENT ASSEMBLY

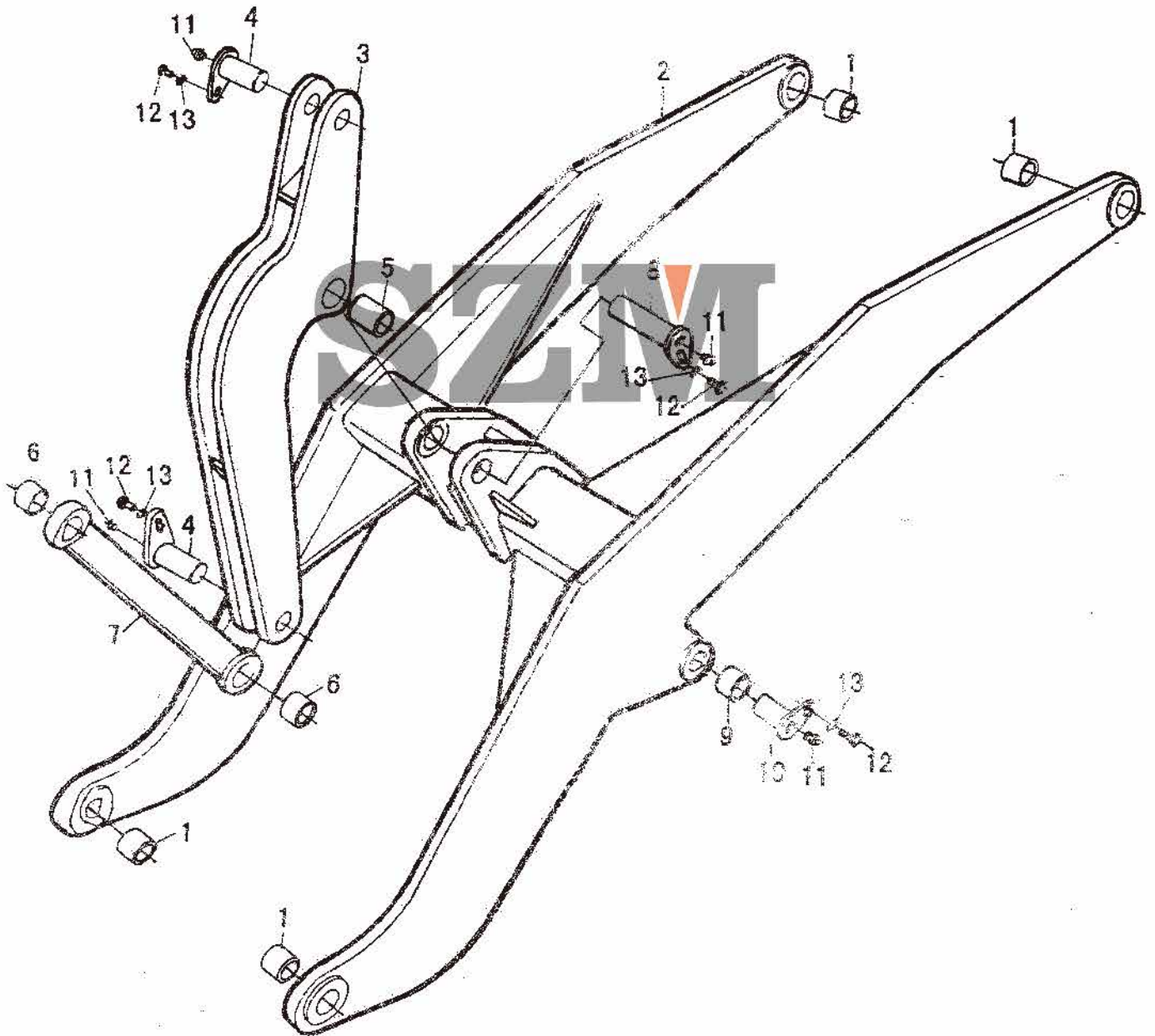

# 青州山装

序号 KEY	件号 PART NO.	名称 DESCRIPTION	数量 QTY
1		衬套 II	4
2		动臂组件	1
3		摇臂组件	1
4		铲斗与拉杆铰接销轴	2
5		衬套 VI	1
6		衬套 III	2
7		拉杆组件	1
8		摇臂与动臂铰接销轴	1
9		衬套 I	2
10		动臂与举升缸铰接销轴	2
11	GB/T7940.1-1995	油杯 M8 × 1	5
12	GB/T5783-2000	螺栓 M10 × 20	5
13	GB/T93-1987	垫圈 10	5

# SZM

配重铁总成

COUNTER WEIGHT ASSEMBLY

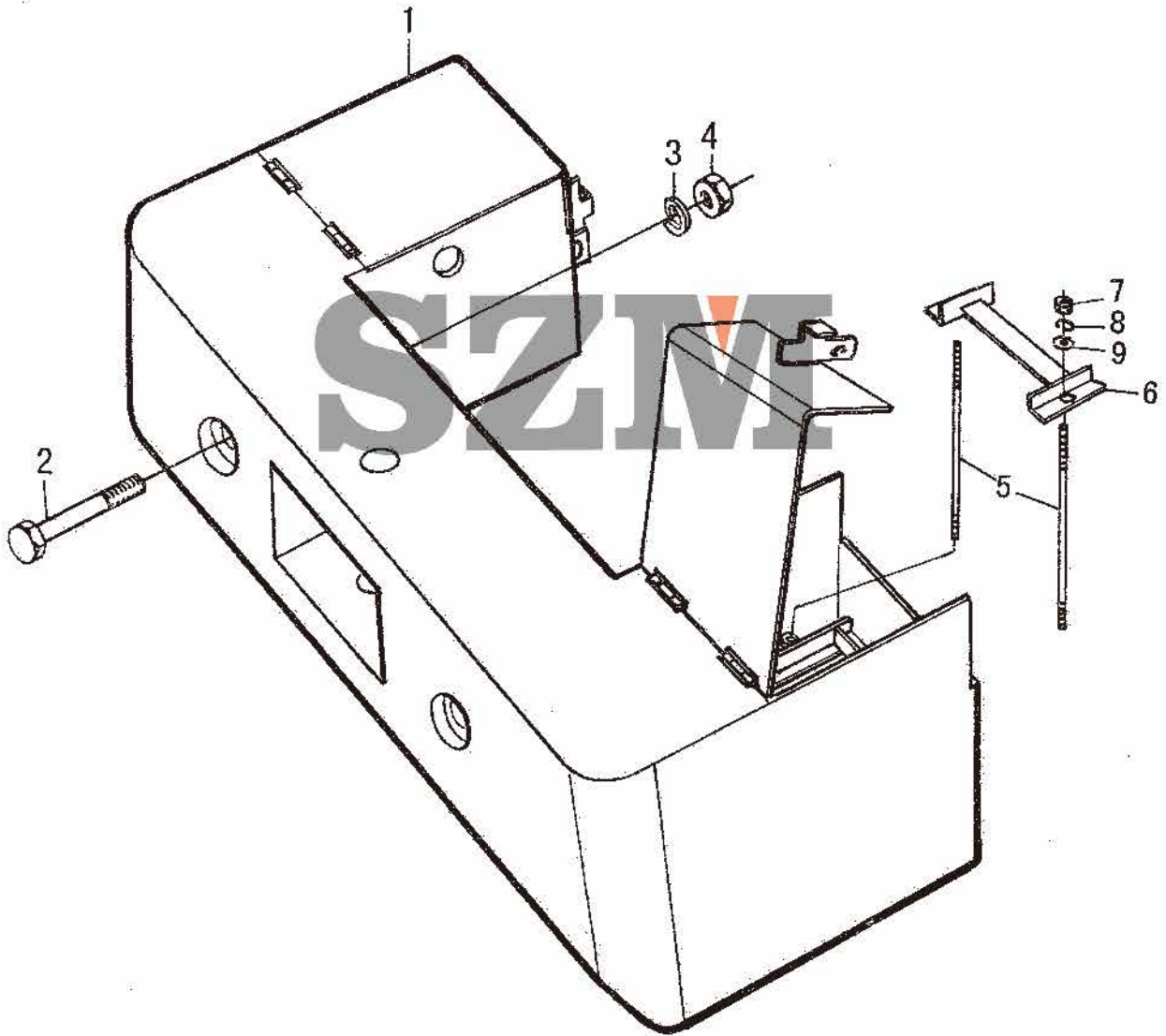

# 青州山装

序号 KEY	件号 PART NO.	名称 DESCRIPTION	数量 QTY	
1		配重铁总成	COUNTER WEIGHT ASS' Y	1
2	GB/T5782-2000	螺栓 M20 × 150	BOLT M20 × 150	2
3	GB/T93-1987	垫圈 20	WASHER 20	2
4	GB/T6170-2000	螺母 M20	NUT M20	2
5		电瓶箱拉杆	CLAMPING BOLT	4
6		电瓶箱压盖	CLAMPING PLATE	2
7	GB/T6170-2000	螺母 M8	NUT M8	4
8	GB/T93-1987	垫圈 8	WASHER 8	4
9	GB/T97.1-2000	垫圈 8	WASHER 8	4

# SZM

发动机罩总成

HOOD OF DIESEL ENGINING

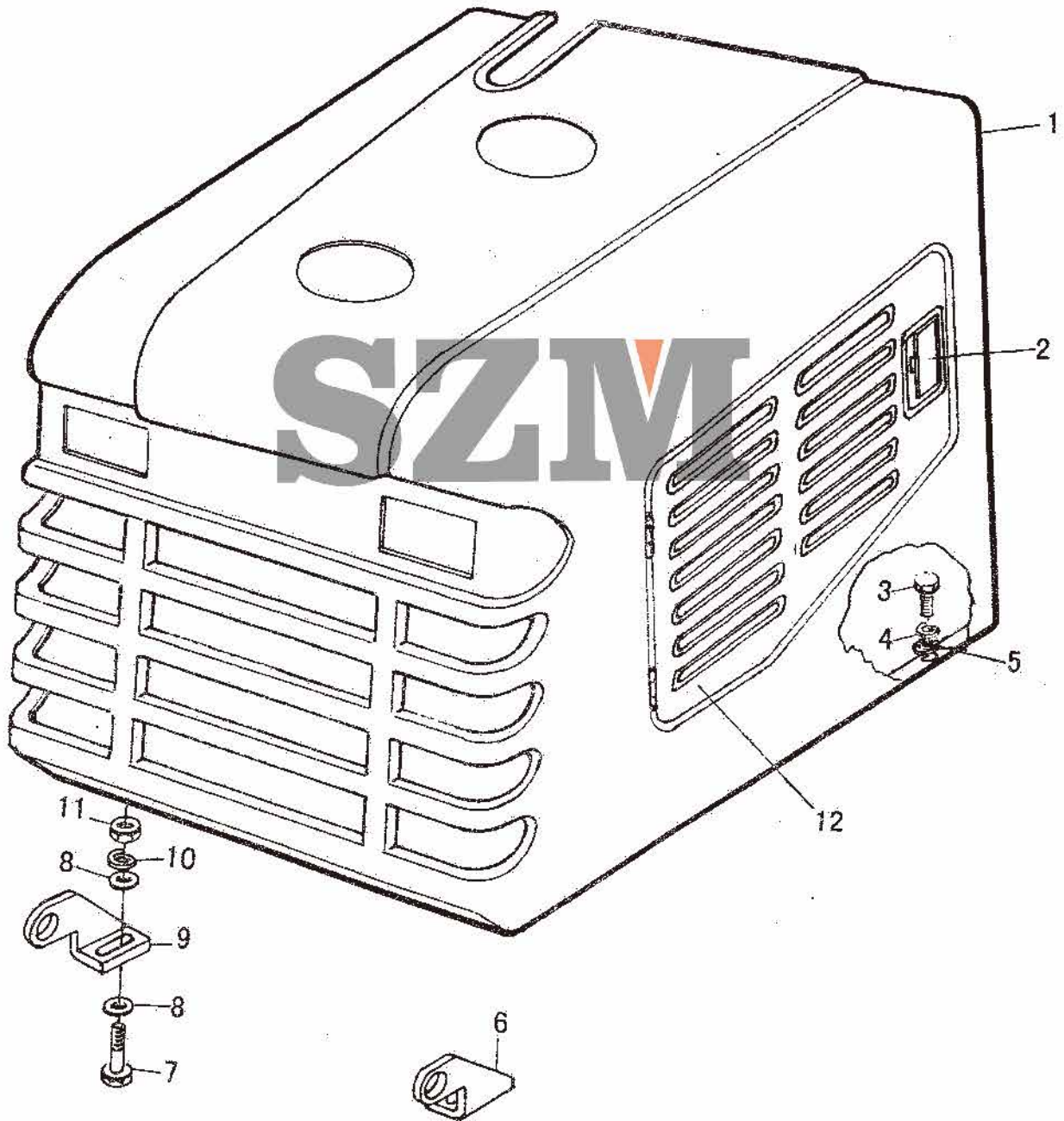



# 青州山装

序号 KEY	件号 PART NO.	名称 DESCRIPTION	数量 QTY	
1		发动机罩	HOOD OF DIESEL ENGINE	1
2		护罩窗锁	WINDOW LOCK	2
3	GB/T5783-2000	螺栓 M8 × 40	BOLT M8 × 40	2
4	GB/T93-1987	垫圈 8	WASHER 8	2
5	GB/T97.1-2000	垫圈 8	WASHER 8	2
6		发动机罩铰连座 (右)	BRACKET(RIGHT)	1
7	GB/T5783-2000	螺栓 M12 × 40	BOLT M12 × 40	2
8	GB/T97.1-2000	垫圈 12	WASHER 12	4
9		发动机罩铰连座 (左)	BRACKET(LEFT)	1
10	GB/T93-1987	垫圈 12	WASHER 12	2
11	GB/T6170-2000	螺母 M12	NUT M12	2
12		护罩窗	WINDOW	2

# SZM

方向盘组合

STEERING WHEEL MODULE

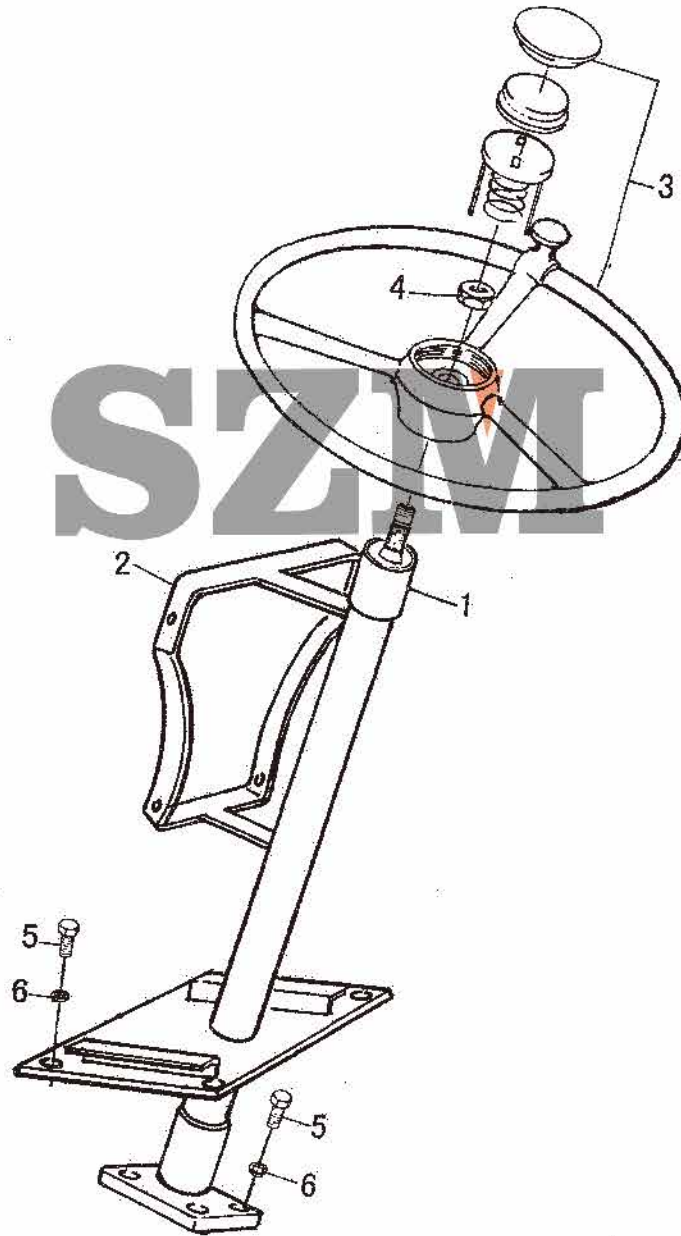

# 青州山装

序号 KEY	件号 PART NO.	名称 DESCRIPTION	数量 QTY
1		转向管柱	1
2		转向管柱支架	1
3		方向盘	1
4		螺母	1
5		螺栓 M10 × 20	8
6		垫圈 10	8

# SZM

转向液压系统

STEERING SYSTEM

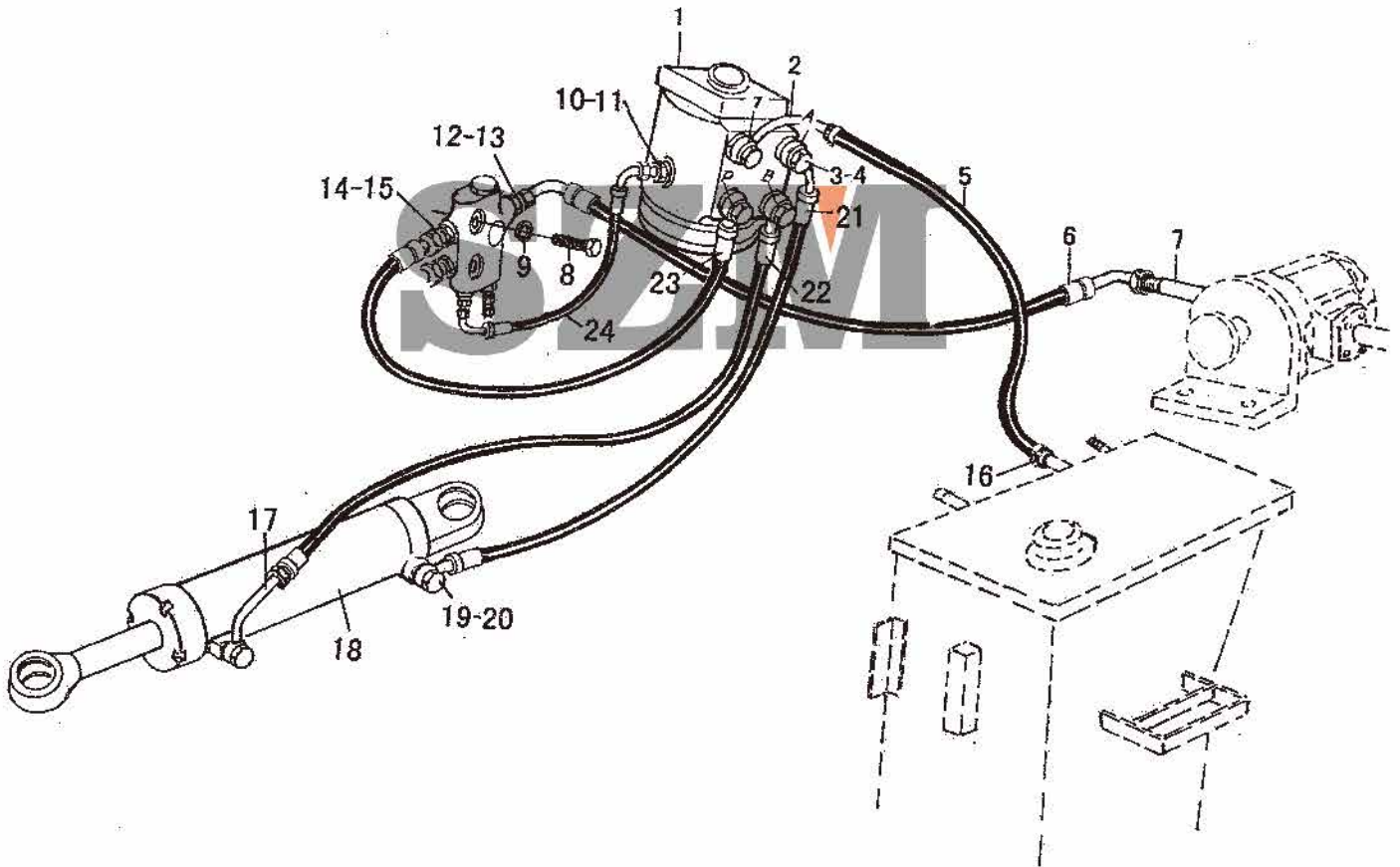

# 青州山装

序号 KEY	件号 PART NO.	名称 DESCRIPTION	数量 QTY
1		转向器 STEERING GEAR	1
2		转向器回油组件 STEERING GEAR CONNECTOR	1
3		转向器空心螺栓 BOLT	4
4		铜垫 20 WASHER 20	8
5		转向器回油低压软管 OIL RETURN PIPE OF STEERING GEAR	1
6		优先阀进油软管 OIL INLET PIPE OF PRIORITY VALVE	1
7		泵出油口 PUMP CONNECTOR	1
8	GB/T5782-2000	螺栓 M8 × 70 BOLT M8 × 70	2
9	GB/T93-1987	垫圈 8 WASHER 8	2
10		转向器接头 CONNECTOR	3
11		铜垫 12 WASHER 12	1
12		优先阀接头 I -CONNECTOR OF PRIORITY VALVE	1
13		铜垫 27 WASHER 27	1
14		优先阀接头 II II -CONNECTOR OF PRIORITY VALVE	1
15		铜垫 22 WASHER 22	1
16	JB/T8870-1999	喉箍 22-32 CLAMP 22-32	1
17		转向缸油管组件 II II -STEERING CYLINDER CONNECTOR	1
18		转向缸 STEERING CYLINDER	1
19		空心螺栓 BOLT	2
20		O型圈 24 O-RING 24	4
21		转向缸后腔软管 REAR-OIL PIPE OF STEERING CYLINDER	1
22		转向缸前腔软管 FORE-OIL PIPE OF STEERING CYLINDER	1
23		转向器进油软管 OIL INLET PIPE OF STEERING	1
24		转向器到优先阀软管 OIL PIPE OF STEERING GEAR TO PRIORITY VALVE	1

# SZM



转向器

ORBIT-ROLL VALVE

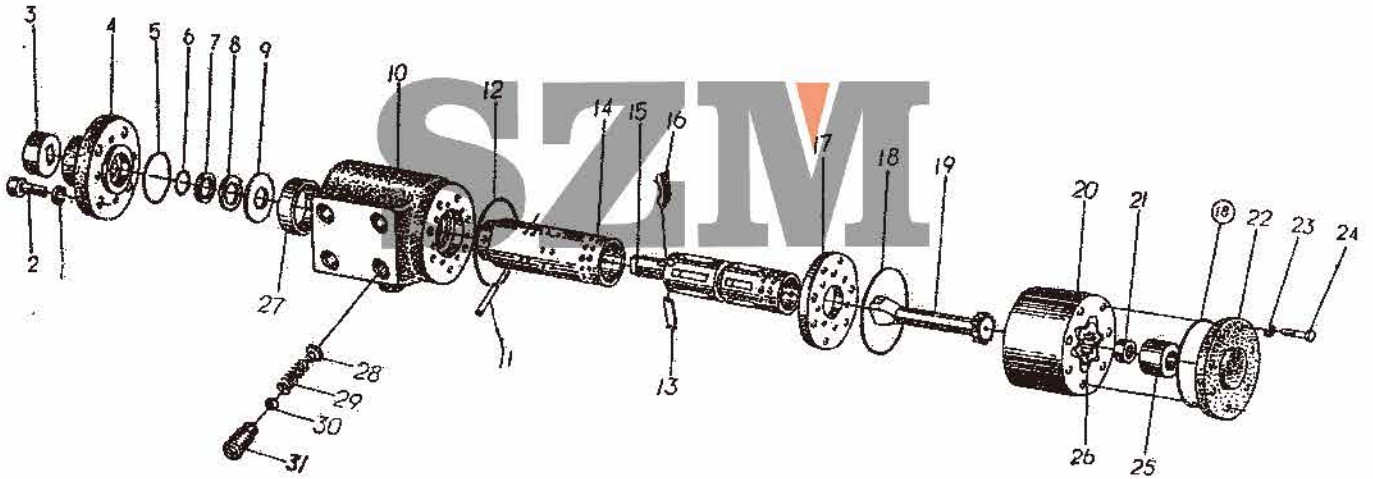

# 青州山装

序号 KEY	件号 PART NO.	名称 DESCRIPTION	数量 QTY
1	GB70-85	内六角螺钉 M8 × 22	4
2	GB93-87	垫圈 8	4
3		连接块	1
4		前盖	1
5	GB3452.1-82	O 型密封圈 43.7 × 2.65	1
6	GB1235-76	O 型密封圈 26 × 2.4	1
7		X 型密封圈	1
8		挡环	1
9		滑环	1
10		阀体	1
11		拔销	1
12	GB3452.1-82	O 型密封圈 80 × 2.65	1
13		隔片	2
14		阀套	1
15		阀芯	1
16		弹簧片	6
17		隔盖	1
18		O 型密封圈	2
19		联动轴	1
20		定子	1
21		限位块	1
22		后盖	1
23		铜垫	7
24		螺栓	6
25		限位柱垫	1
26		转子	1
27		挡圈	1
28		弹簧座	1
29		弹簧	1
30	GB308-64	钢球	1
31		单向阀体	1

优先阀总成

PRIORITY VALVE ASSEMBLY

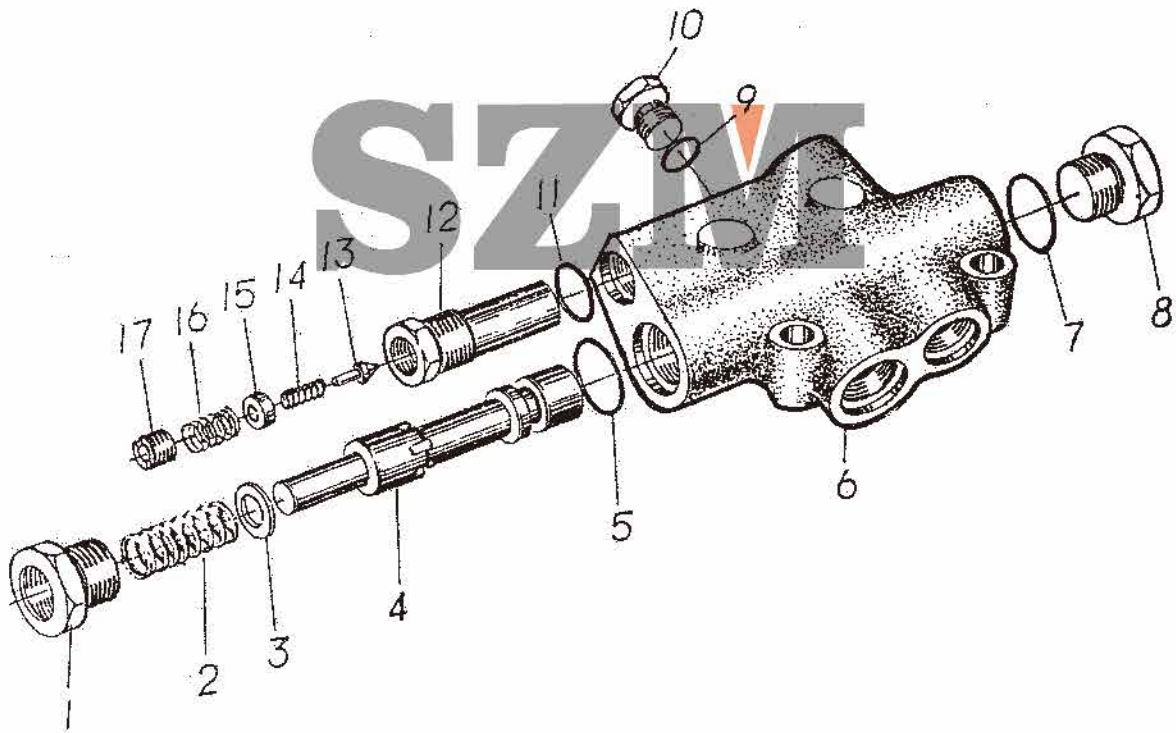

# 青州山装

序号 KEY	件号 PART NO.	名称 DESCRIPTION	数量 QTY
1		接头 CONNCTOR	1
2		弹簧 SPRING	1
3		挡圈 SPACER	1
4		阀杆 VALVE ROD	1
5		O型圈 O-RING	1
6		阀体 VALVE BODY	1
7		O型圈 O-RING	1
8		螺钉 SCREW	1
9		O型圈 O-RING	1
10		放气螺丝 THREAD PLUG	1
11		O型圈 O-RING	1
12		压套 SLEEVE	1
13		导阀 VALVE SPOOL	1
14		导阀弹簧 SPRING	1
15		挡环 SPACER	1
16		弹簧 SPRING	1
17		螺丝 THREAD PLUG	1

# SZM

转向油缸  
STEERING

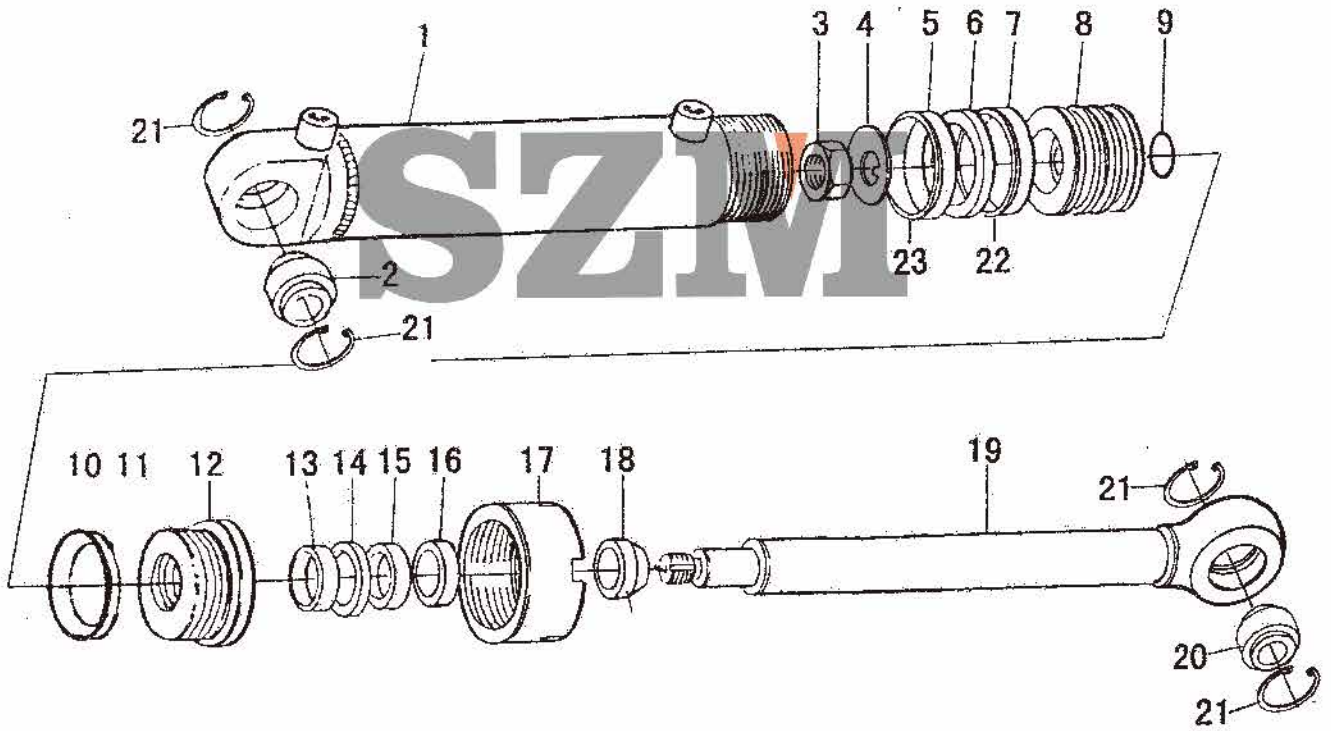



# 青州山装

序号 KEY	件号 PART NO.	名称 DESCRIPTION	数量 QTY
1		转向缸缸体	1
2		冶金套	1
3		压帽	1
4		止退垫	1
5		Y型圈	1
6		格莱圈	1
7		Y型圈	1
8		活塞	1
9		O型圈	1
10		Y型圈	1
11		O型圈	1
12		导向套	1
13		Y型圈	1
14		斯特封	1
15		O型圈	1
16		支承环	1
17		压帽	1
18		防尘圈	1
19		活塞杆	1
20		关节轴承	1
21		卡簧	1
22		挡片	1
23		挡片	1

# SZM

工作装置液压系统

IMPLEMENT HYDRAULIC SYSTEM

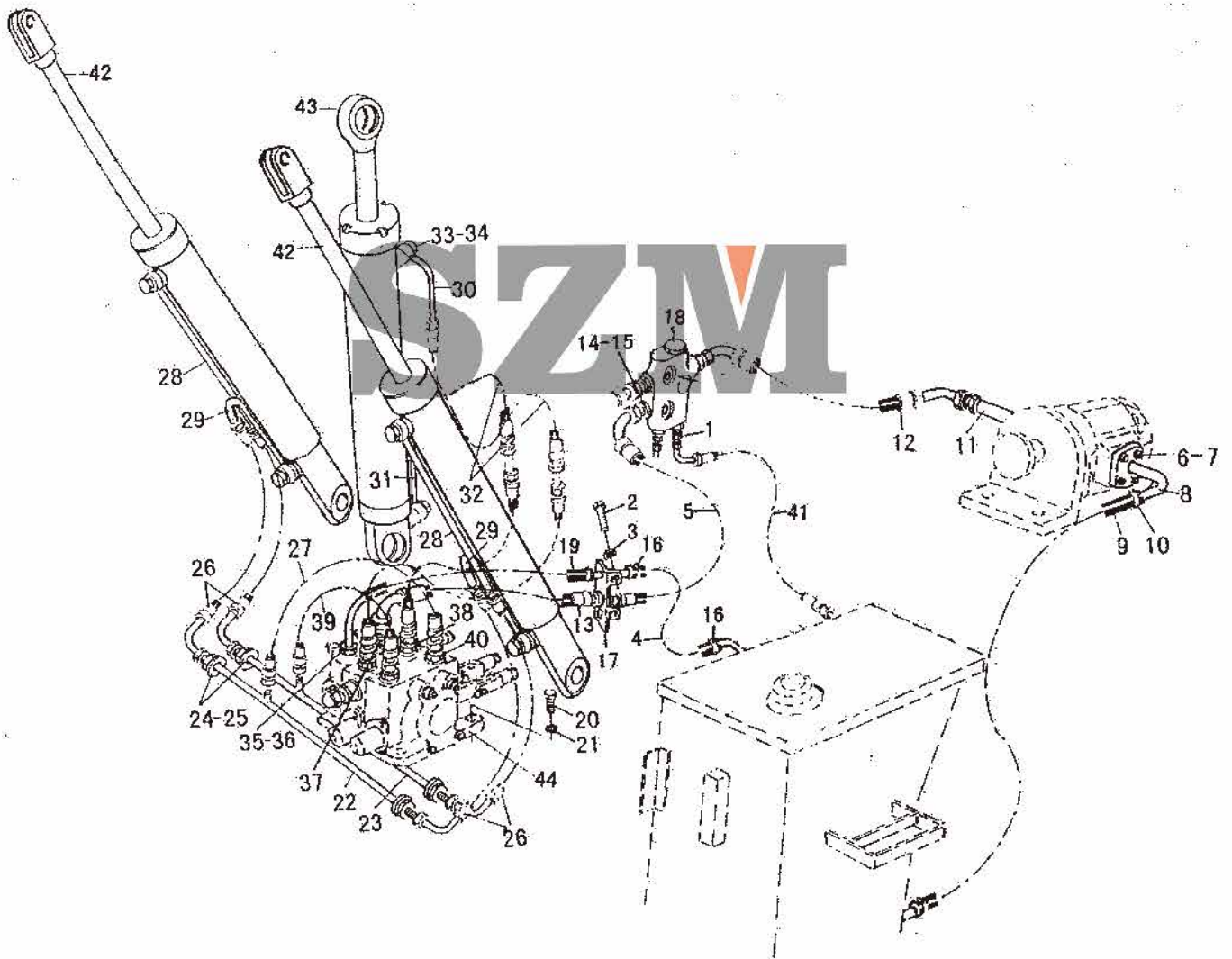

# 青州山装

序号 KEY	件号 PART NO.	名称 DESCRIPTION	数量 QTY	
1		转向器接头	CONNECTOR OF STEERING CEAR	3
2	GB/T5783-2000	螺栓 M8 × 25	BOLT M8 × 25	2
3	GB/T93-1987	垫圈 8	WASHER 8	2
4		油路板组件回油箱低压软管	RETURN OIL HOSE OF HYDRAULIC TANK	1
5		优先阀到油路板组件软管	INPUT TUBE OF PRIORITY VALVE	1
6	GB/T5783-2000	螺栓 M10 × 30	BOLT M8 × 30	8
7	GB/T93-1987	垫圈 10	WASHER 10	8
8		泵进油口	CONNECTOR	1
9		泵进油低压软管	OIL INLET PIPE OF GEAR PUMP	1
10	JB/T8870-1999	喉箍 35-51	CLAMP 35-51	2
11		泵出油口	CLONNE CTOR	1
12		优先阀进油软管	OIL INLET PIPE OF PRIORITY VALVE	1
13		油路板组件到多路阀软管	OIL INLET PIPE OF VALVE	1
14		优先阀接头 I	I -CONNECTOR	1
15		铜垫 27	WASHER 27	1
16	JB/T8870-1999	喉箍 22-32	CLAMP 22-32	4
17		油路板组件	CLAMP PING PLATE	1
18		优先阀	PRIDRITY VALVE	1
19		多路阀回油路板组件低压软管	OIL PIPE OF CONTROL VALVE	1
20	GB/T5783-2000	螺栓 M12 × 50	BOLT M12 × 50	4
21	GB/T93-1987	垫圈 12	WASHER 12	4
22		三通油管 I	I -THREE-WAYOILTUBE	1
23		三通油管 II	THREE-WAYOIL TUBE	1
24		前车架垫圈	WASHER	2
25		螺母 M22 × 1.5	NUT M22 × 1.5	2
26		举升缸油管	OIL PIPE OF LIFTING CLPINDER	4
27		多路阀到三通管 I 软管	I OIL PIPE OF VALVE TO THREE-WAYOIL TUBE	1
28		举升缸油管组件 I	I -OIL PIPE OF LIFTING CYDINDER	2
29		举升缸油管组件 II	II -OIL PIPE OF LIFTING CYDINDER	2
30		翻斗缸油管组件 I	I -OIL PIPE OF DUMP CYDINDER	1
31		翻斗缸油管组件 II	II -OIL PIPE OF DUMP YDINDER	1
32		翻斗油管	OIL PIPE OF DUMP CYDINDER	4
33		空心螺栓 M18 × 1.5	BOLT M18 × 1.5	6
34		O 型圈 24	O-RING 24	12
35		多路阀接头 I	I -CONNECTOR	1
36		铜垫 22	WASHER 22	6
37		多路阀接头 III	III -CONNECTOR	1
38		多路阀接头 I	I -CONNECTOR	2
39		多路阀到三通管 II	II -PIL PIPE OF VALVE TO THREE-WAY OIL TUBE	1
40		多路阀接头 II	II -CONNECTOR	2
41		优先阀回油箱软管	RETURN OIL HOSE OF HYDRAULIC TANK	1
42		举升油缸	LIFT ARM CYLINDER	2
43		翻斗油缸	DUMP CYLINDER	1
44		多路换向阀	MULTI-WAY VALVE	1

翻斗油缸

DUMP CYINDER

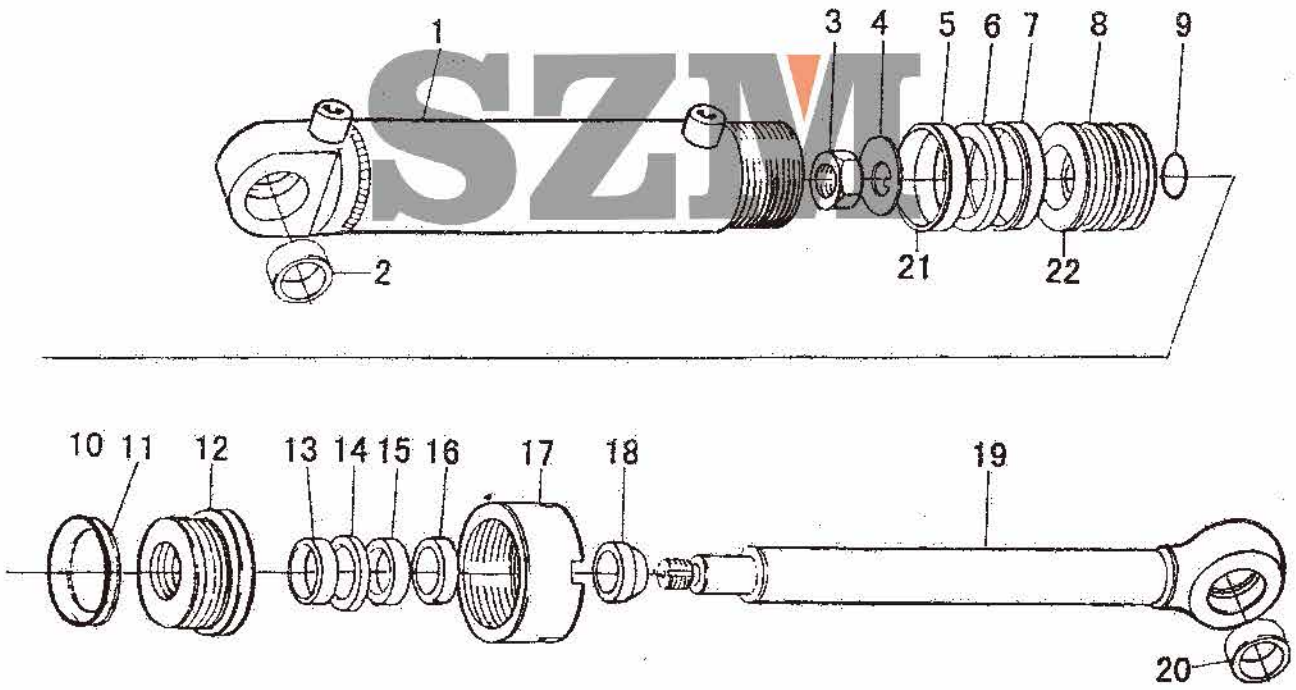

# 青州山装

序号 KEY	件号 PART NO.	名称 DESCRIPTION	数量 QTY
1		翻斗缸缸体	1
2		冶金套	1
3		罗帽	1
4		止退垫	1
5		Y型圈	1
6		格莱圈	1
7		Y型圈	1
8		活塞	1
9		O型圈	1
10		Y型圈	1
11		O型圈	1
12		导向套	1
13		Y型圈	1
14		斯特封	1
15		O型圈	1
16		支承环	1
17		压帽	1
18		防尘圈	1
19		活塞杆	1
20		冶金套	1
21		挡片	1
22		挡片	1

# SZM



动臂油缸

LIFT ARM CYINDER

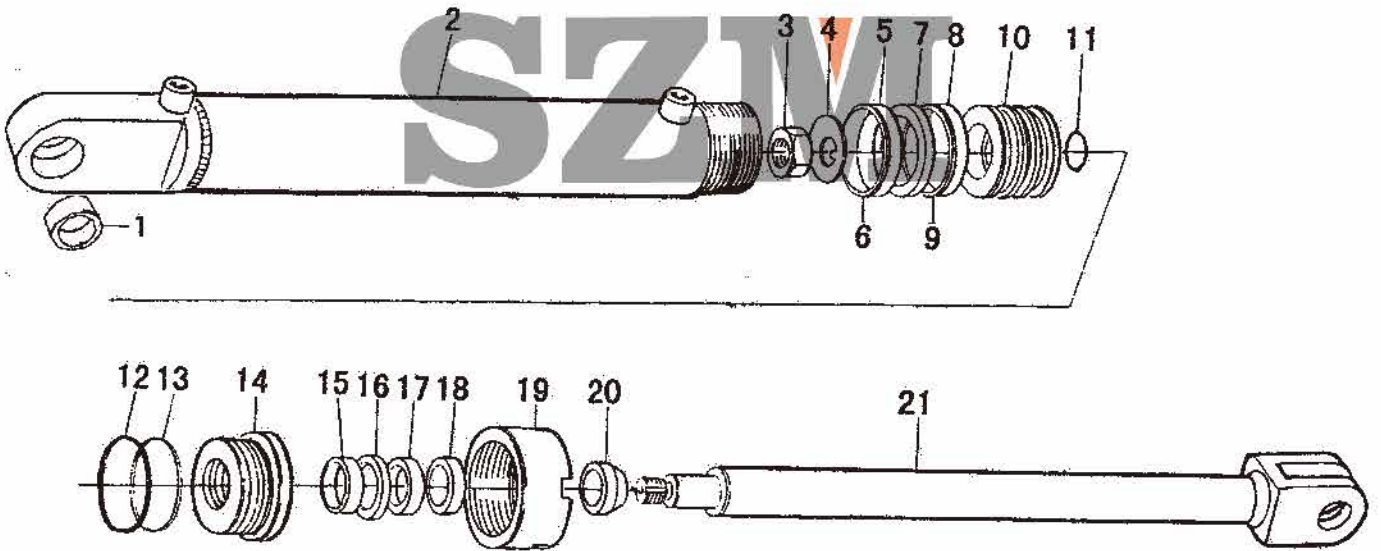

# 青州山装

序号 KEY	件号 PART NO.	名称 DESCRIPTION	数量 QTY
1		冶金套 BUSHING	1
2		半升缸缸体 CYLINDER BODY	1
3		螺帽 LOCKING NUT	1
4		止退垫 LOCKING WASHER	1
5		Y型圈 Y-RING	1
6		挡片 SNAP RING	1
7		格莱圈 SEAL RING	1
8		Y型圈 Y-RING	1
9		挡片 SNAP RING	1
10		活塞 PISTON	1
11		O型圈 O-RING	1
12		Y型圈 Y-RING	1
13		O型圈 O-RING	1
14		导向套 BUSHING	1
15		Y型圈 Y-RING	1
16		斯特封 FABRICATE SEALING	1
17		O型圈 O-RING	1
18		支承环 SUPPORTING RING	1
19		压帽 CYLINDER NUT	1
20		防尘帽 DUST PROOF RING	1
21		活塞杆 PISTON ROD	1

# SZM

齿轮泵  
GEAR PUMP

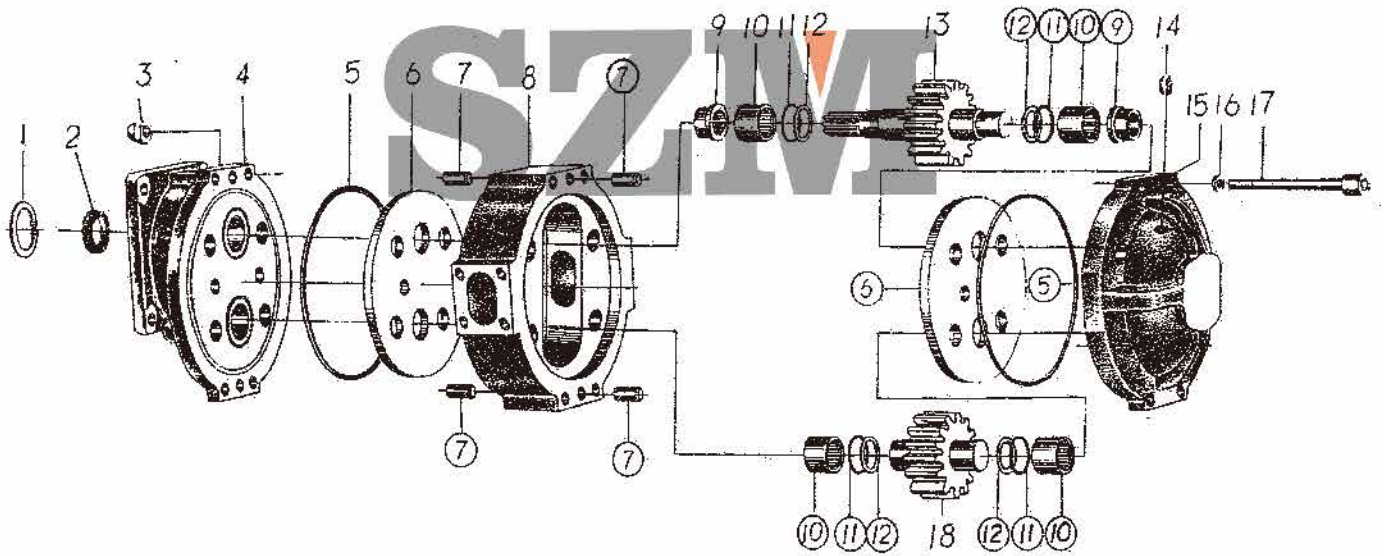

# 青州山装

序号 KEY	件号 PART NO.	名称 DESCRIPTION	数量 QTY
1	GB893.1-86	挡圈 A42	1
2		骨架油封 SD25 × 45 × 10 × 12	1
3		螺母	1
4	CBG1-03	前盖	1
5		O型圈	2
6	CBG1-08	侧板	2
7	GB119-86	销	4
8	CBG1050-08	泵体	1
	CBG1025-07	泵体	1
	CBG1016-06	泵体	1
9	CBG1-02	密封环	2
10		滚针轴承	4
11	CBG1-04	密封圈	4
12	CBG1-05	挡圈	4
13	CBG1-07	主动齿轮轴	1
14	CBG1-13	堵塞	1
15	CBG1-10	后盖	1
16	CBG1-14	垫圈	4
17	GB70-85	螺钉 M14 × 75	4
		螺钉 M14 × 85	4
		螺钉 M14 × 90	4
18	CBG1-09	从动齿轮轴	1

# SZM

油泵传动轴支架

SUPPORT, DRIVING SHAFT OF PUMP

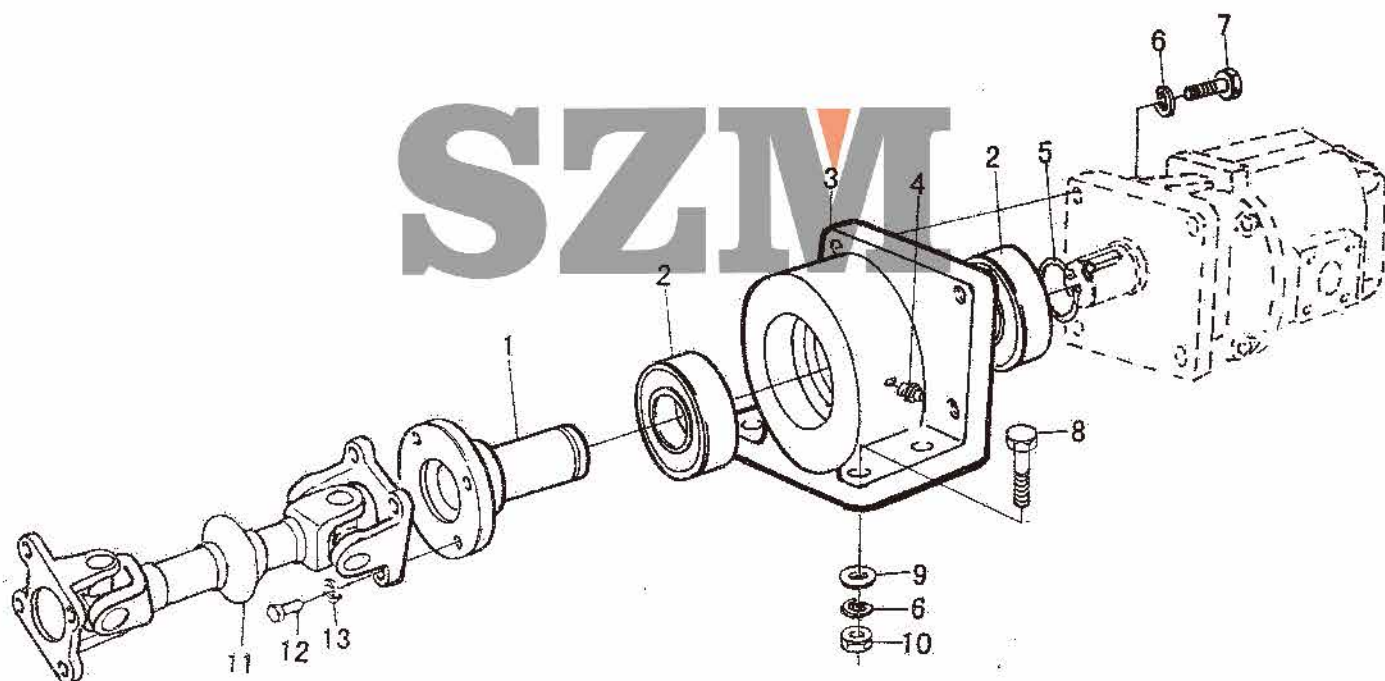



# 青州山装

序号 KEY	件号 PART NO.	名称 DESCRIPTION	数量 QTY
1		油泵连接法兰	1
2	GB/T276-94	轴承 6209	2
3	WYL4.0-E.16-8	油泵连接盘	1
4	JB/T7940.1-1995	油杯 M10 × 1	1
5	GB894.1-86	挡圈 d42	1
6	GB/T93-1987	垫圈 12	8
7	GB/T5783-2000	螺栓 M12 × 40	4
8	GB/T5783-2000	螺栓 M12 × 50	4
9	GB/T97.1-2000	垫圈 12	4
10	GB/T6170-2000	螺母 M12	4
11		泵传动轴总成	1
12	GB/T5783-2000	螺栓 M8 × 30	8
13	GB/T93-1987	垫圈 8	8

# SZM

多路阀

LOADER VALVE ASSEMBLY

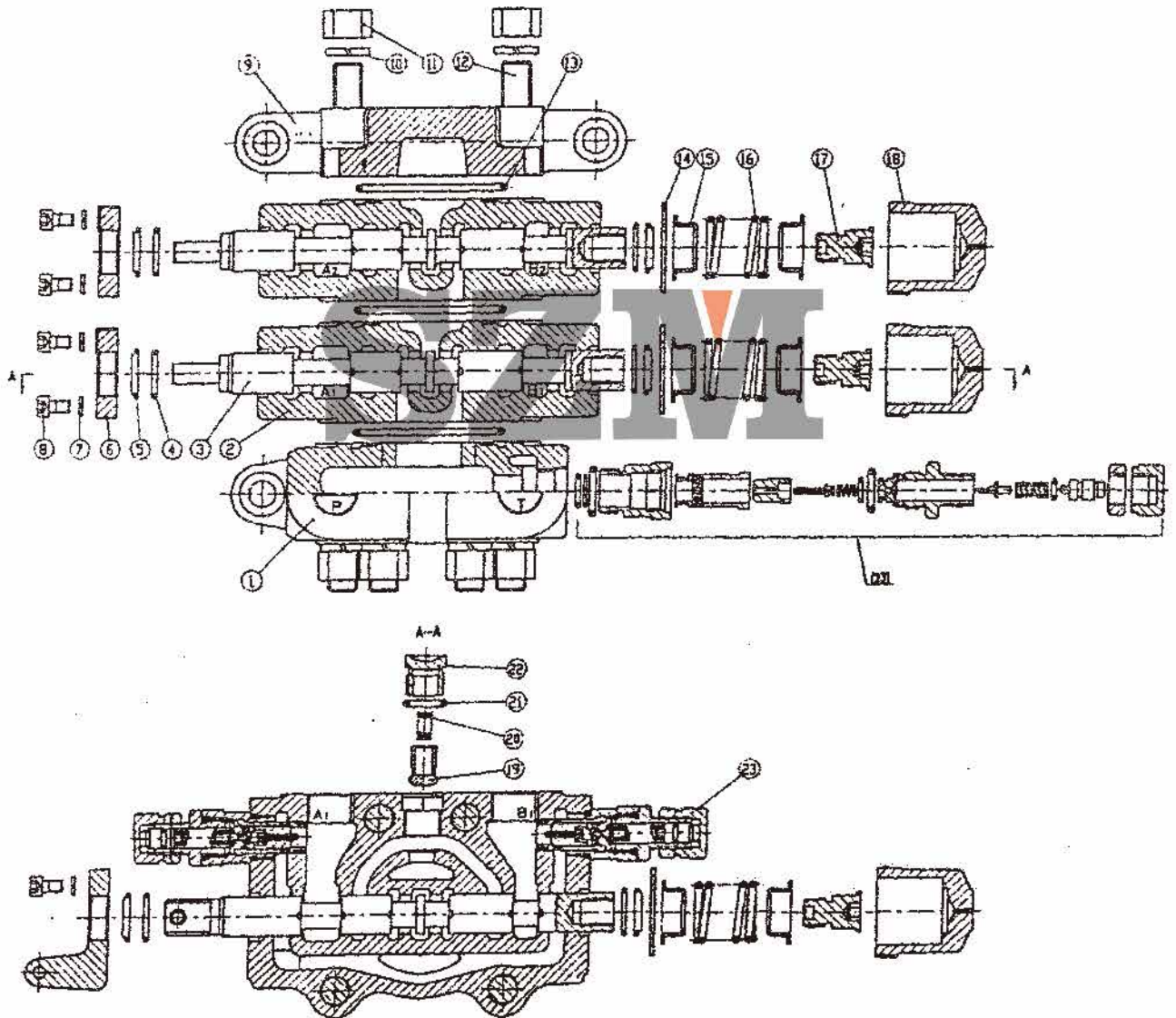

# 青州山装

序号 KEY	件号 PART NO.	名称 DESCRIPTION	数量 QTY
1		进油阀体	1
2		换向阀体	2
3		阀杆 (O形)	2
4	GB1235-76	O型密封圈 24 × 2.4	4
5		防尘圈	4
6		手柄架	2
7	GB93-87	垫圈 6	8
8	GB70-85	螺钉 M6	8
9		回油阀体	1
10	GB93-87	垫圈 14	8
11	GB6175-86	螺母 M14	8
12		联接螺栓	4
13	GB1235-76	O型密封圈 75 × 3.1	3
14		挡板	2
15		弹簧座	4
16		复位弹簧	2
17		复位柱	2
18		端盖	2
19		单向阀	2
20		单向阀弹簧	2
21	GB1235-76	O型密封圈	2
22		单向阀盖	2
23		安全阀 (过载阀) 组件	3

# SZM

安全阀

SAFETY VALVE

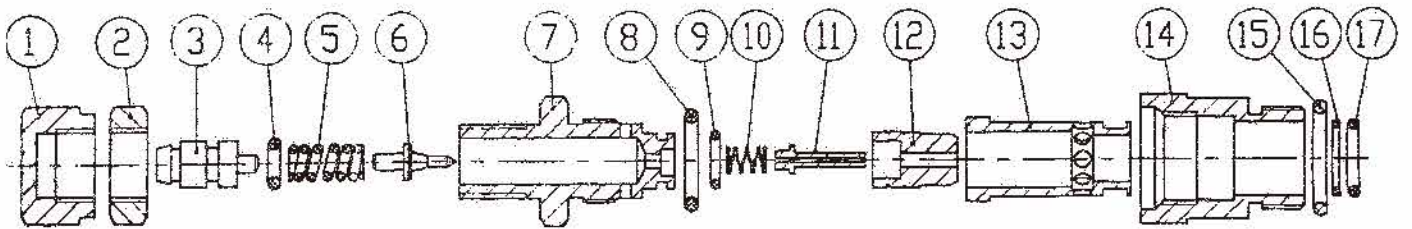
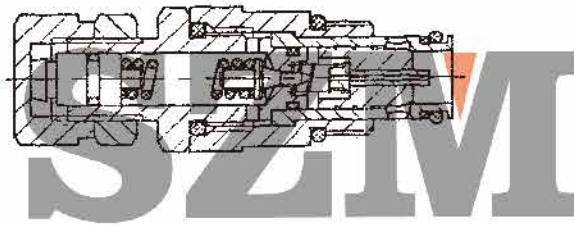

# 青州山装

序号 KEY	件号 PART NO.	名称 DESCRIPTION	数量 QTY
1		调压螺母	1
2		锁紧螺母	1
3		柱塞	1
4	GB1235-76	O型密封圈 10 × 1.9	1
5		调压弹簧	1
6		提动阀	1
7		提动阀座	1
8	GB1235-76	O型密封圈 22 × 2.4	1
9	GB1235-76	O型密封圈 12 × 1.9	1
10		复位弹簧	1
11		滑阀	1
12		锥阀	1
13		阀套	1
14		螺纹接套	1
15	GB1235-76	O型密封圈 24 × 2.4	1
16		挡圈	1
17	GB1235-76	O型密封圈 16 × 1.9	1

# SZM



工作操纵机构

WORKING CONTROL SYSTEM

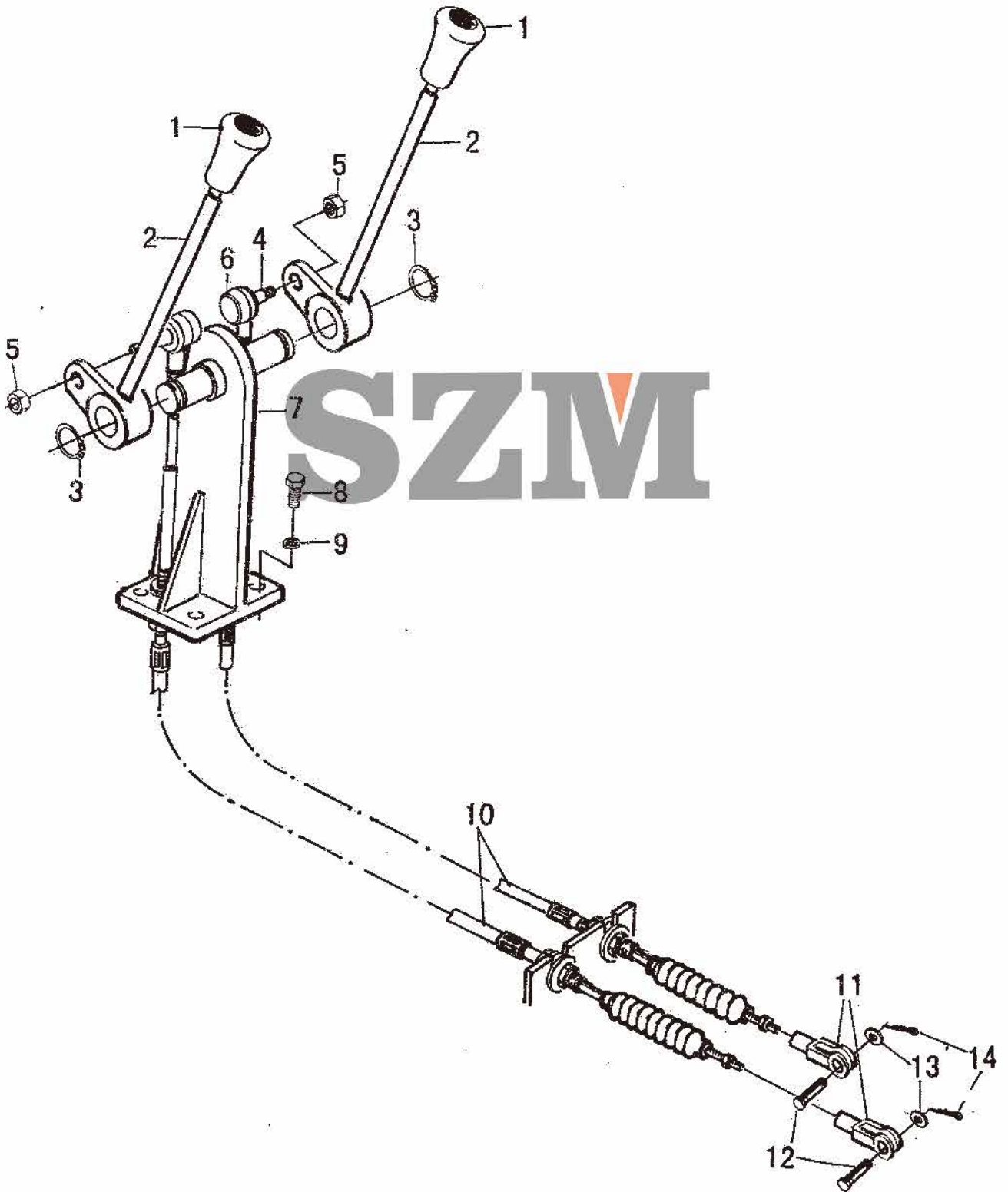

# 青州山装

序号 KEY	件号 PART NO.	名称 DESCRIPTION	数量 QTY
1		操纵手球	2
2		工作阀组件 II	2
3	GB894.1-86	挡圈 14	2
4	GB/T5783-2000	螺栓 M10 × 30	2
5	GB/T8170-2000	螺母 M10	2
6	SI 10T/K	杆端轴承	2
7		工作阀组件 I	1
8	GB/T5783-2000	螺栓 M8 × 25	4
9	GB/T93-1987	垫圈 8	4
10		操纵软轴	2
11		阀操纵拉叉	2
12		销子 6 × 30	2
13	GB/T97.1-2000	垫圈 6	2
14	GB/T91-2000	开口销 2.8	2

# SZM

机油箱总成

ENGINE OIL TANK ASSEMBLY

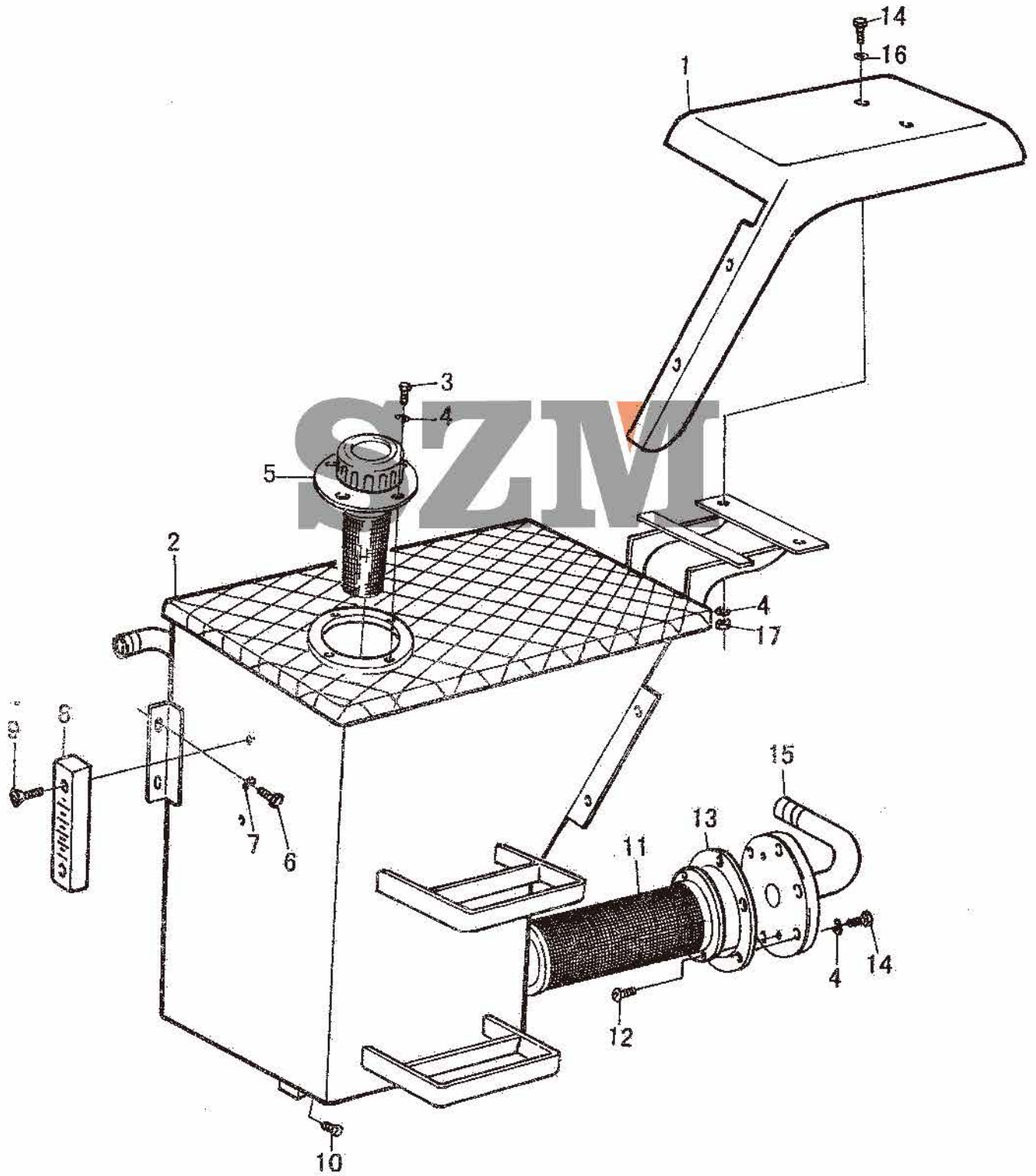

# 青州山装

序号 KEY	件号 PART NO.	名称 DESCRIPTION	数量 QTY
1		后挡泥瓦 (右)	1
2		机油箱	1
3	GB/T5783-2000	螺栓 M8 × 15	4
4	GB/T93-1987	垫圈 8	14
5		加油口滤网组件	1
6	GB/T5783-2000	螺栓 M14 × 30	4
7	GB/T93-1987	垫圈 14	4
8		机油箱液位计	1
9		油标固定螺栓	2
10	WYL3.0-E.8-1	放油阀芯	1
11		出油口滤网	1
12	GB/T68-2000	螺钉 M5 × 10	2
13		出油口橡胶垫	1
14	GB/T5783-2000	螺栓 M8 × 30	10
15		吸油口组件	1
16	GB/T97.1-2002	垫圈 8	4
17	GB/T6170-2000	螺母 M8	4

# SZM

柴油箱总成

FUEL TANK ASSEMBLY

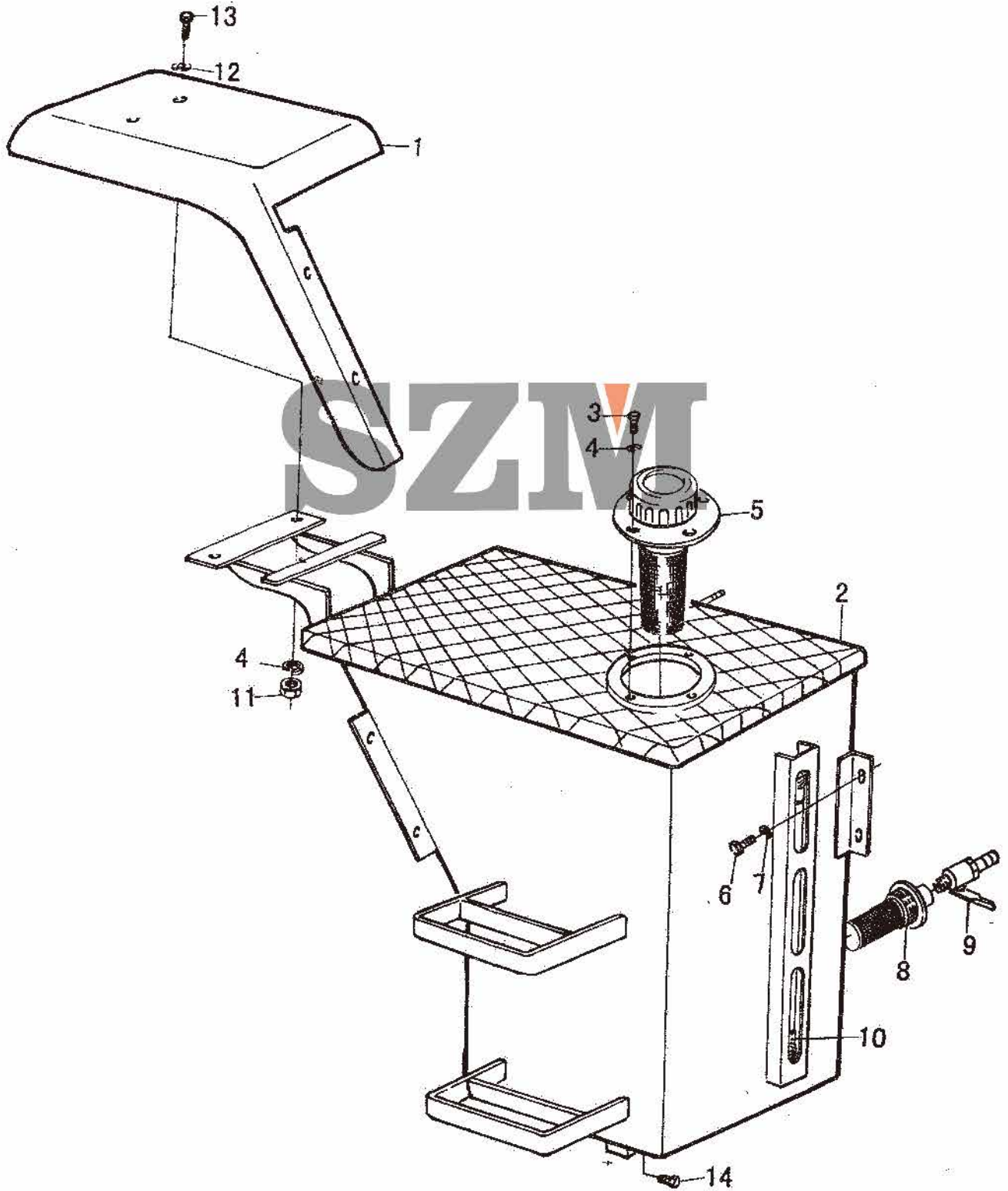



# 青州山装

序号 KEY	件号 PART NO.	名称 DESCRIPTION	数量 QTY
1		后泥挡瓦 (左)	1
2		柴油箱	1
3	GB/T5783-2000	螺栓 M8 × 15	4
4	GB/T93-1987	垫圈 8	8
5		加油口滤网组件	1
6	GB/T5783-2000	螺栓 M14 × 30	4
7	GB/T93-1987	垫圈 14	4
8		出油口滤网	1
9		柴油箱出油口	1
10		柴油液位计	1
11	GB/T6170-2000	螺母 M8	4
12	GB/T97.1-2002	垫圈 8	4
13	GB/T5783-2000	螺栓 M8 × 30	4
14	WYL3.0-E.8-1	放油阀芯	1

# SZM

操纵台总成

CONSOLE SUPPORT ASSEMBLY

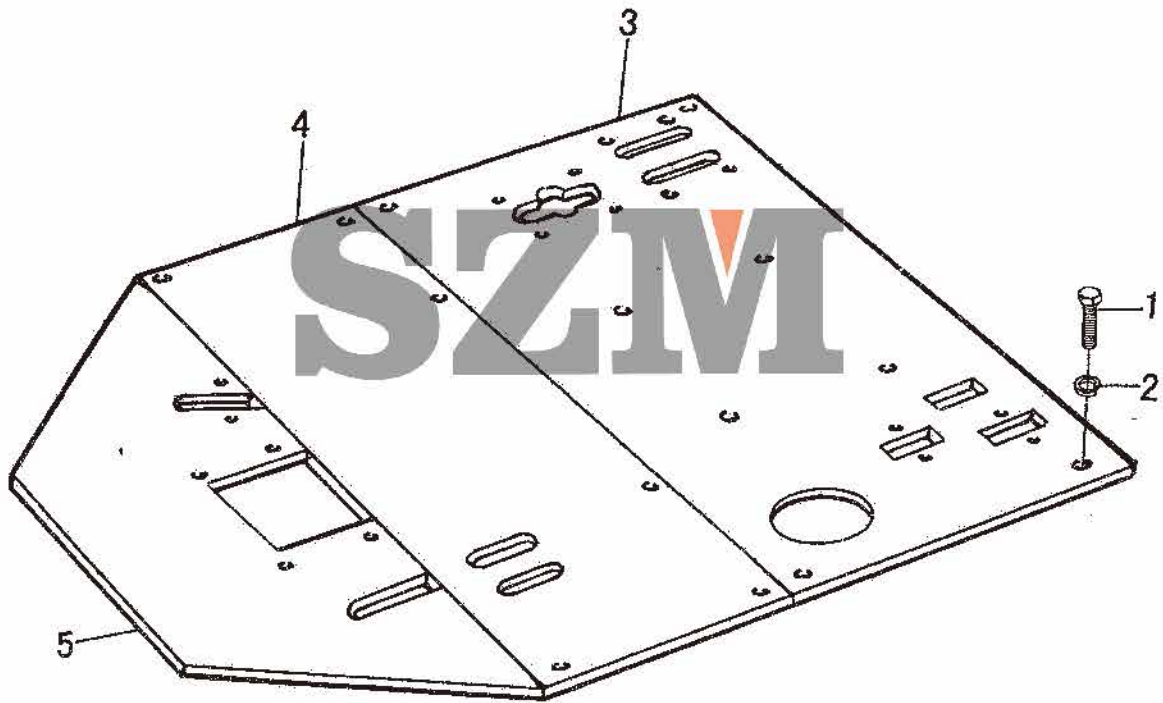

# 青州山装

序号 KEY	件号 PART NO.	名称 DESCRIPTION	数量 QTY	
1	GB/T5783-2000	螺栓 M8 × 20	BOLT M8 × 20	8
2	GB/T93-1987	垫圈 8	WASHER 8	8
3		后地板组件	REAR FLOOR MODULE	1
4		中地板	MID FLOOR MODULE	1
5		前地板	FRONT FLOOR MODULE	1

# SZMI

驾驶室总成

CAGE ASSEMBLY

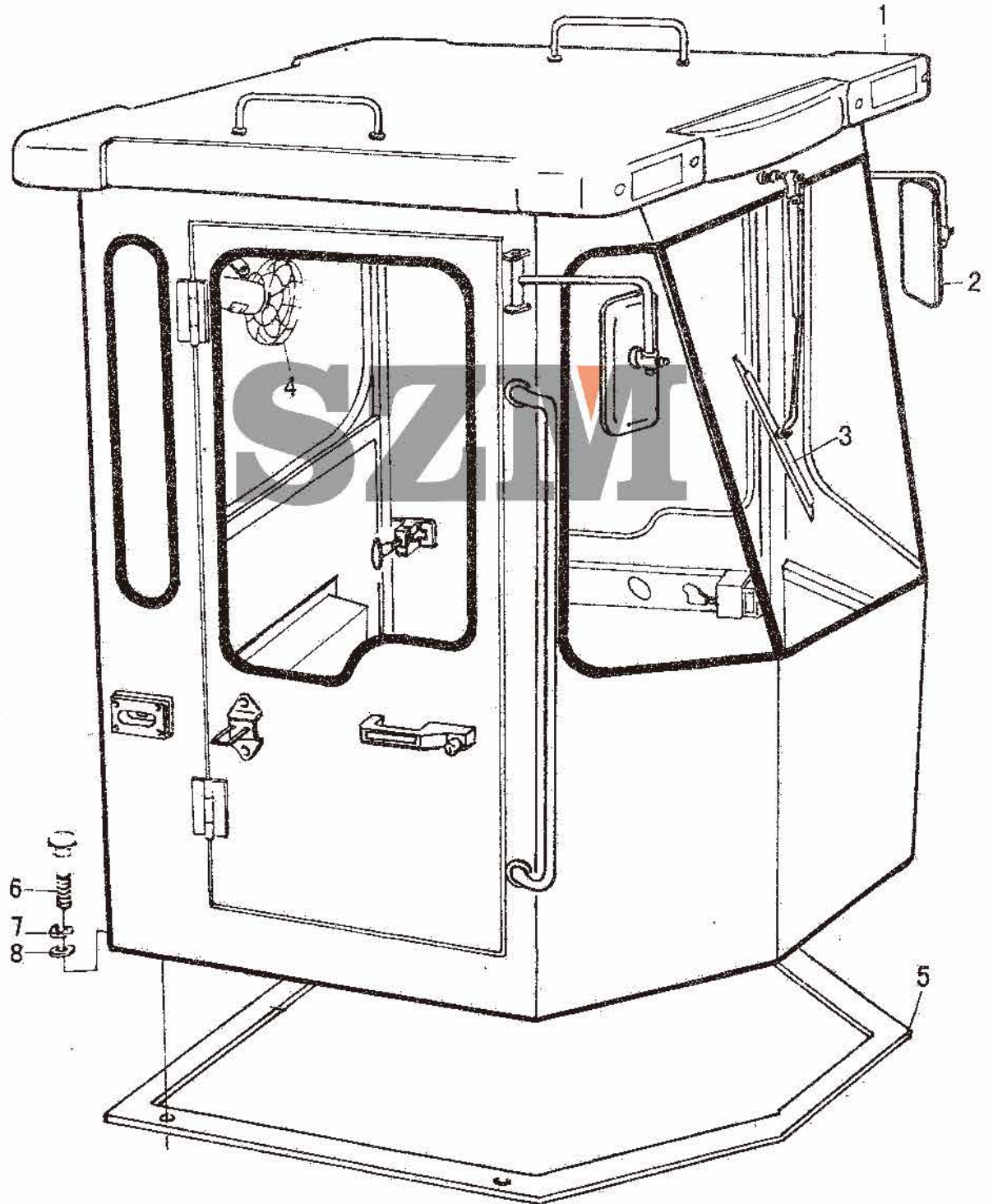

# 青州山装

序号 KEY	件号 PART NO.	名称 DESCRIPTION	数量 QTY
1		驾驶室 CAGE	1
2		反光镜 REVERSE MIRROR ASS' Y	2
3		刮雨器 WIPER	1
4		风扇 FAN	1
5		防震垫 RUBBER SPACER	1
6	GB/T5783-2000	螺栓 M10 × 40 BOLT M10 × 40	4
7	GB/T93-1987	垫圈 10 WASHER 10	4
8	GB/T97.1-2002	垫圈 12 WASHER 12	4

# SZM



座椅总成

SEAT ASSEMBLY

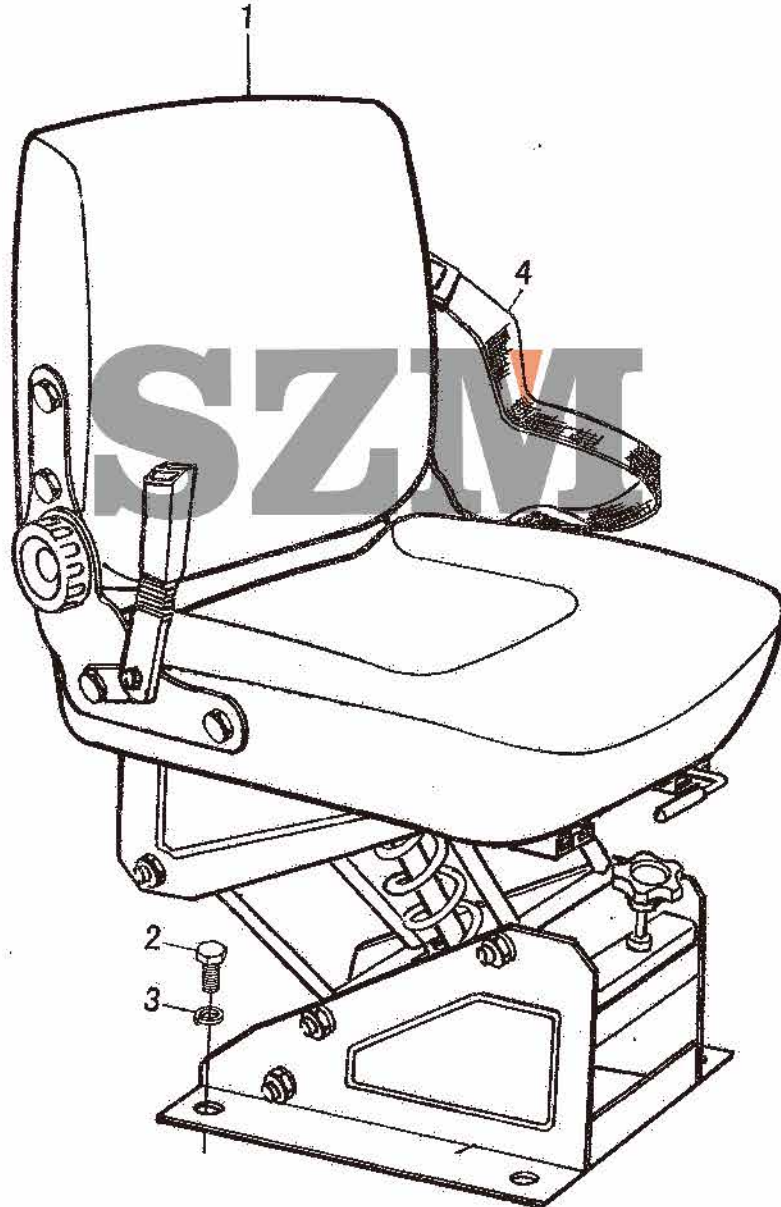

# 青州山装

序号 KEY	件号 PART NO.	名称 DESCRIPTION	类 Q
1		座椅总成	SEAT ASSEMBLY
2	GB/T5783-2000	螺栓 M12 × 20	BOLT M8 × 25
3	GB/T93-1987	垫圈 12	WASHER 12
4		安全带	SAFETY BLET

# SZM

驾驶室操纵台

CAGE GROUP CONSOLE SUPPORT

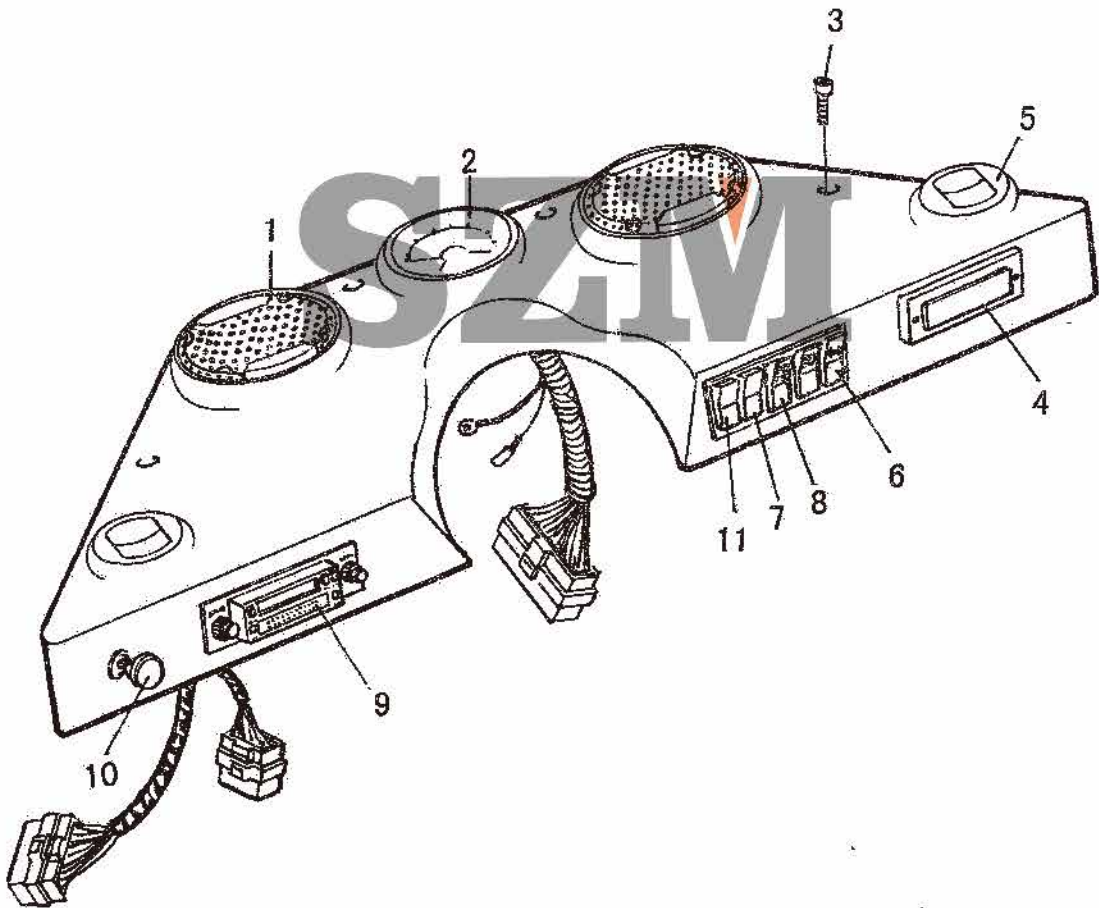

# 青州山装

序号 KEY	件号 PART NO.	名称 DESCRIPTION	数量 QTY	
1		喇叭	TRUMPET	2
2		机油压力表	ENGINE OIL MANOMETER	1
3		内六角螺丝	HEXANGULAR SCREW OF INSIDE	4
4		烟灰缸	ASHTRAY	1
5		暖风口	GENIAL BREEZES	1
6		转向灯开关	TURN TO FACE THE LIGHT SWITCH	1
7		暖风开关	GENIAL BREEZES SWITCH	1
8		前大灯开关	EX-HEADLIGHT SWITCH	1
9		收音机	RADIO	1
10		点烟器	POINT SMOKE DEVICE	1
11		雨刮喷水开关	WIPER WATER SWITCH	1

# SZM

仪表盘总成

CONTROL PANEL ASSEMBLY

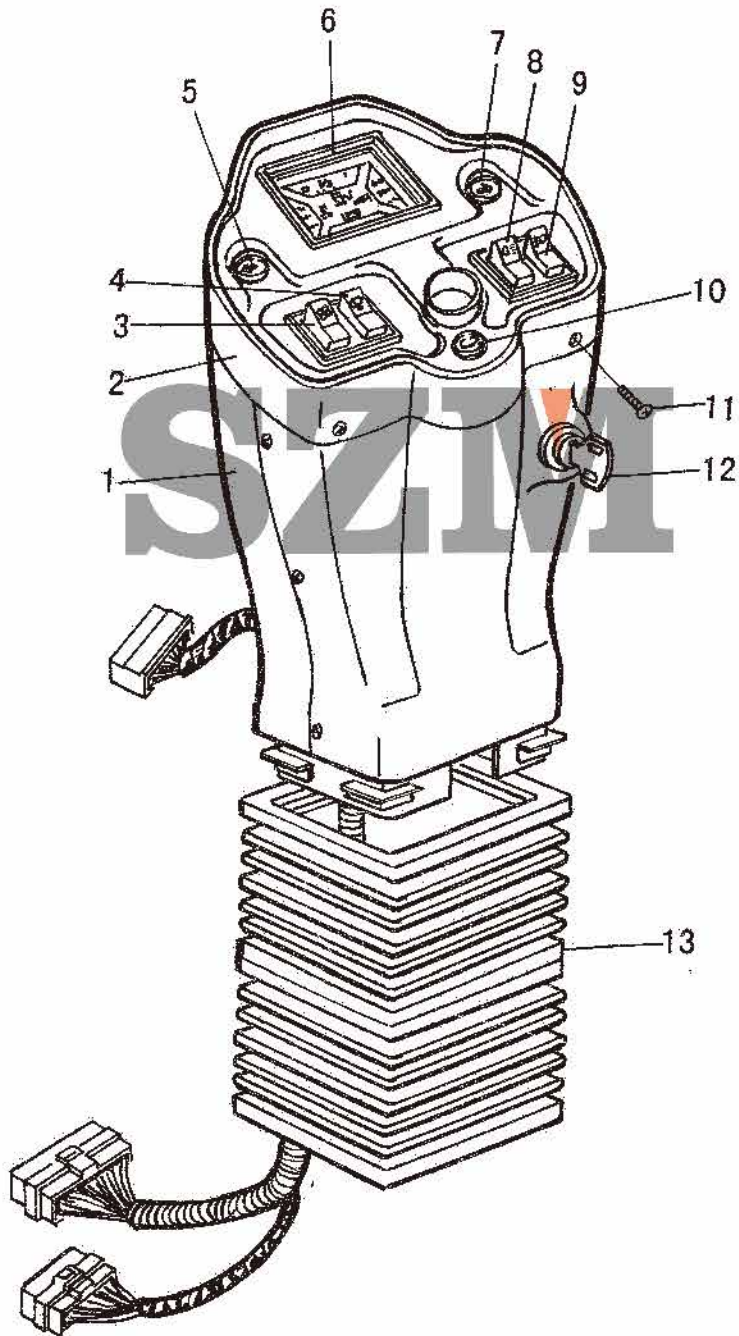



# 青州山装

序号 KEY	件号 PART NO.	名称 DESCRIPTION	数量 QTY
1		仪表盘外壳 I	1
2		仪表盘外壳 II	1
3		风扇开关	1
4		雨刮器开关	1
5		左转向指示灯	1
6		仪表盘	1
7		右转向指示灯	1
8		后大灯开关	1
9		顶灯开关	1
10		刹车指示灯	1
11		螺钉	14
12		电锁	1
13		胶皮套	1

# SZM

电气系统

ELECTRIC SYSTEM

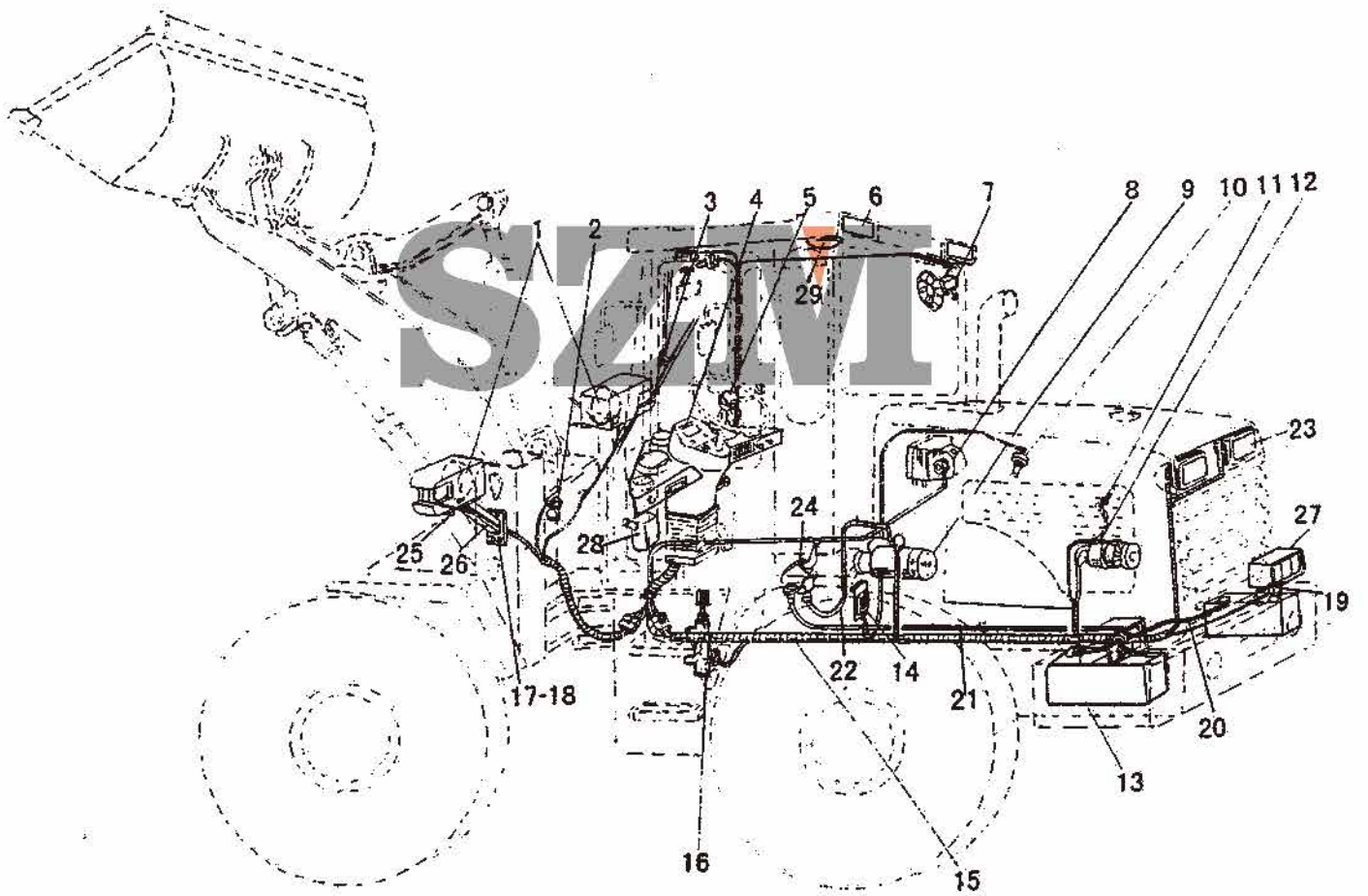

# 青州山装

序号 KEY	件号 PART NO.	名称 DESCRIPTION	数量 QTY
1		前大灯总成	2
2		喇叭	1
3		刮雨器	1
4		仪表盘总成	1
5		喇叭按钮	1
6		后大灯	1
7		电风扇	1
8		电暖风	1
9		起动机	1
10		油温传感器	1
11		水温传感器	1
12		发电机	1
13		蓄电池	2
14		电子调节器	1
15		车架线束总成	1
16		车架线束总成	1
17		垫圈 8	10
18		螺栓 M8 × 16	4
19		接地线	1
20		蓄电池连接线	1
21		蓄电池与电源开关连接线	1
22		蓄电池与起动机连接线	1
23		后尾灯	2
24		电源开关	1
25		螺栓 M8 × 25	6
26		灯架	2
27		后组合灯	2
28		除霜洗涤剂总成	1
29		顶棚灯 (带内视镜)	1

**SZM**

**QINGZHOU SHANZHUANG MACHINERY CO.,LTD.**

Add: No.1 Yintai street Qingzhou North Road,Qingzhou ,  
Shandong,china.

Tel (Fax): +86-536-6131728 3526015

mobile: +86-13953626023 13793661507

Web: [www.cszmc.com](http://www.cszmc.com)

QQ: 1665589999

E-mail:[cszmc@hotmail.cn](mailto:cszmc@hotmail.cn)